

**KEITH Mfg. Co.**  
World Headquarters  
800-547-6161  
541-475-3802  
541-475-2169 fax

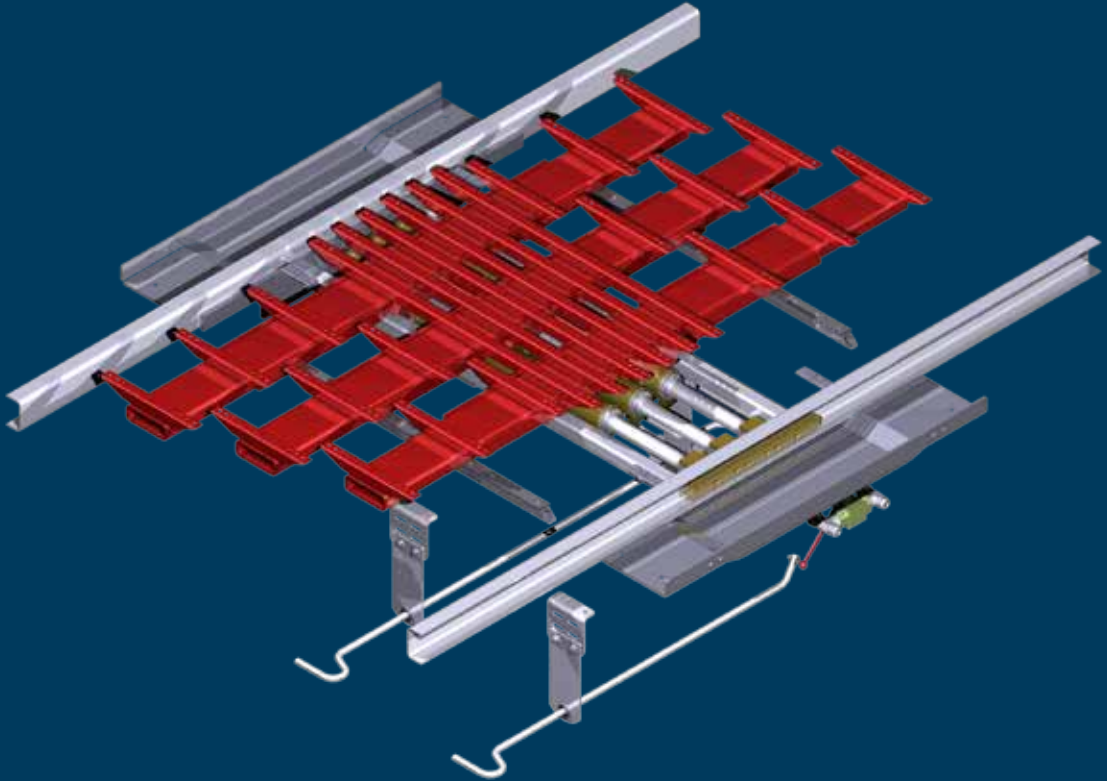

## **KEITH® RUNNING FLOOR II® OWNERS MANUAL Original Instructions**

**High Quality Ball Seal  
Advanced Switching Valve  
Center Frame Design  
Cross-Drive Support  
Winged Bearings  
Snapdown Bearings & flooring**

**Interchangeable Cylinders  
External Check Valves  
No Hydraulic Hoses  
Strong Drive Frame  
Compact Design  
Double Rod Wipers Protect Seals**



KEITH Mfg. Co.  
WORLD HEADQUARTERS  
401 N.W. Adler St.  
Madras, OR 97741  
(800) 547-6161  
(541) 475-3802  
(541) 475-2169 fax  
sales@keithwalkingfloor.com

[www.keithwalkingfloor.com](http://www.keithwalkingfloor.com)

We at KEITH Mfg. Co. are very happy that you have decided to equip your trailer with the KEITH® RUNNING FLOOR II® unloading system. We take great pride in the fact that we manufacture the simplest and lowest maintenance self-unloading system available. Installing the KEITH® RUNNING FLOOR II® unloader in your trailer provides you with the versatility to load or unload virtually any type of material.

The following pages contain information on the operation of your KEITH® RUNNING FLOOR II® unloader.

In addition, we have provided information on the type of hydraulic wet kit that will be needed on your tractor. **Please be sure to use the recommended pumps, filters and pressure relief valves listed, or approved equivalent equipment. It is critical to adhere to the outlined hydraulic wet kit specifications. Failure to follow the guidelines concerning required operation pressures can lead to your system operating improperly.**

Please review the entire manual before operating the KEITH® RUNNING FLOOR II® unloading system. If you have any questions or concerns, do not hesitate to contact our factory toll-free at 800-547-6161 or via email at [techdept@keithwalkingfloor.com](mailto:techdept@keithwalkingfloor.com) and our trained personnel will be happy to assist you.

Thank you again for equipping your trailer with a KEITH® RUNNING FLOOR II® unloader.

Sincerely,

Keith Foster  
Founder

Mark Foster  
President

**WARRANTY AND SAFETY**

Warranty..... 2  
 Safety..... 3  
 Safety Decals..... 4

**OPERATION**

Safe Start-Up/Shut Down..... 5  
 Driver Check List..... 6  
 Operation of Your Running Floor II® Unloader..... 7  
 Component Location Guide..... 8  
 How It Works..... 9  
 Plumbing Diagram..... 11  
 Start-Up Check List..... 11  
 Wet Kit Diagram..... 12  
 Floor Speed..... 12  
 Wet Kit Information..... 13

**TROUBLESHOOTING**

Switching Valve Adjustment..... 14  
 Switching Valve Troubleshooting..... 16  
 Check Valve Troubleshooting..... 17  
 Replacing a Check Valve..... 18  
 Control Valve, Ball Valve Troubleshooting..... 19  
 Hydraulic Cylinders Troubleshooting..... 20  
 Repairing Cylinders..... 21  
 KEITH® RUNNING FLOOR II® Oil Flow Diagram..... 22  
 Suggested Preventive Maintenance Schedule..... 23

**PARTS**

Drive Frame & Related Components..... 24  
 Cross-Drive Assembly..... 26  
 Cylinder Assembly..... 28  
 Hydraulic Tubes & Fittings..... 30  
 Check Valve Assembly..... 32  
 Control Valve Assembly..... 34  
 Switching Valve Assembly..... 36  
 Ball Valve Assembly..... 38  
 Front Shield Assembly..... 39  
 Floor Components..... 40

**MAINTENANCE AND WARRANTY**

Maintenance for New Systems..... 42  
 Warranty Registration..... 43

**Note:** The following parts guide is for the KEITH® RUNNING FLOOR II® 24 slat system. For all other systems please contact KEITH Mfg. Co. at 800-547-6161.



KEITH Mfg. Co.  
WORLD HEADQUARTERS  
401 N.W. Adler St.  
Madras, OR 97741  
(800) 547-6161  
(541) 475-3802  
(541) 475-2169 fax  
sales@keithwalkingfloor.com

[www.keithwalkingfloor.com](http://www.keithwalkingfloor.com)

## WARRANTY

**KEITH Mfg. Co.** hereby warrants, only to the first owner of a new **KEITH® WALKING FLOOR®** unloader from the factory or selling distributor that the product shall be free from defects in material and workmanship for a period of one year after delivery to the first registered owner. This warranty does not cover normal wear and tear and maintenance and is not to be construed as a service contract.

**Owners Obligation:** To qualify for warranty coverage, a warranty card must be completed and on file at KEITH Mfg. Co. and the equipment must be subject to normal use and service only.

**Definition of Normal Use and Service:** Normal use and service means the loading and/or unloading of uniformly distributed, non-corrosive material, properly restrained and secured, on properly maintained public roads, with gross vehicle weights not in excess of factory rated capacity. For stationary installations, normal use and service means the conveying of uniformly distributed, non-corrosive materials, with weights not in excess of factory rated capacity.

**Sole and Exclusive Remedy:** If the product covered hereby fails to conform to the above stated warranty, **KEITH Mfg. Co.'s** sole liability under this warranty and the owner's sole and exclusive remedy is limited to repair or replacement of the defective part(s) at a facility authorized by **KEITH Mfg. Co.** This is the owner's sole and exclusive remedy for all contract claims, and all tort claims including those based on the strict liability in tort and negligence. Any defective part(s) must be shipped prepaid to KEITH Mfg. Co., Madras, OR.

**Except As Expressly Set Forth Above, KEITH Mfg. Co. Makes No Warranties:** Express, implied or statutory, specifically, no warranties of fitness for a particular purpose or warranties of merchantability are made. Further, **KEITH Mfg. Co.** will not be liable for incidental damages or consequential damages such as, but not limited to, loss of use of the product, damage to the product, towing expenses, attorney's fees and the liability you may have in respect to any other reason.

**Tort Disclaimer:** KEITH Mfg. Co. shall not have any liability in tort with respect to the products, including any liability based on strict liability in tort and negligence.

**If This Warranty Violates Law:** To the extent any provision of this warranty, contravenes the law of any jurisdiction, that provision shall be inapplicable in such jurisdiction and the remainder of the warranty shall not be affected thereby.

## To Prevent Possible Injury or Death

1. **Do Not** Operate the floor with the doors closed.
2. **Do Not** Stand behind the trailer or in the discharge area when the floor is operating.
3. **Do Not** Make adjustments to the unloading mechanism with the floor operating.
4. **Do Not** Operate unloader when protective covers and screens are not in place.
5. **Do Not** Go underneath the trailer when floor is operating.
6. **Do Not** Leave the trailer unattended while the unloader is in operation.

### **Always:**

1. Disengage the trailer from the (P.T.O.) hydraulic power unit before service and maintenance.
2. Shut off the power supply before going underneath the trailer.
3. Stay away from any oil leaks when hydraulic pressure is high.
4. Shut off the hydraulic power take off unit (P.T.O.) before moving the trailer.
5. Make certain no one is in the trailer during loading.

**!!Keep your hands, body parts and loose clothing away from the floor slats and drive mechanism when the unloading system is in operation!!**

Each decal notifies the operator of instructions or potential safety hazards associated with the KEITH® *WALKING FLOOR*® unloader. If your dealer has not placed the decals during installation, please follow the decal placement guide provided and place the decals as directed. If you have not been provided with the operational and safety decals, please contact your dealer, or KEITH Mfg. Co. directly and we will provide a set of decals for your application and use. If you have any questions or concerns regarding the decal placement, please don't hesitate to contact your dealer or KEITH Mfg. Co.

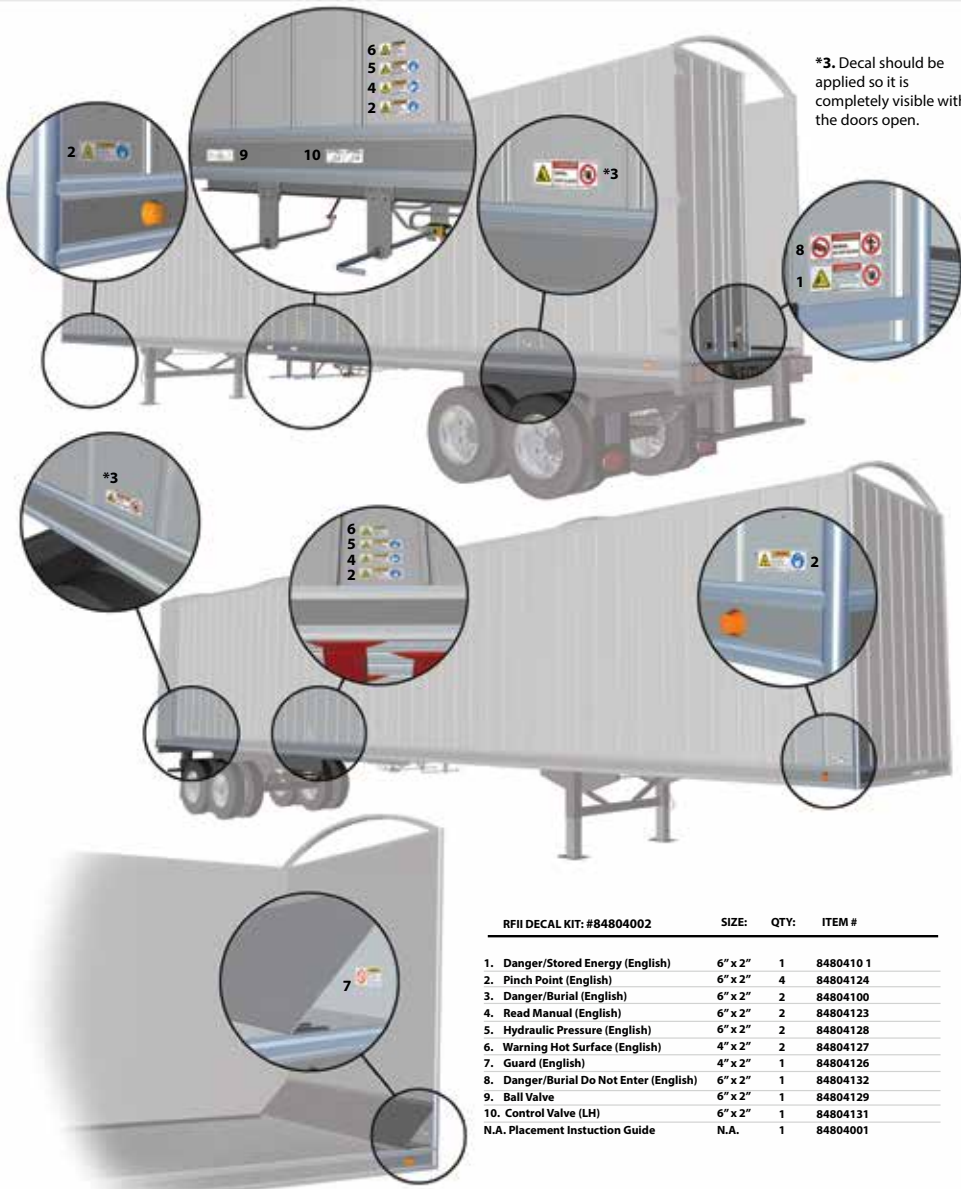
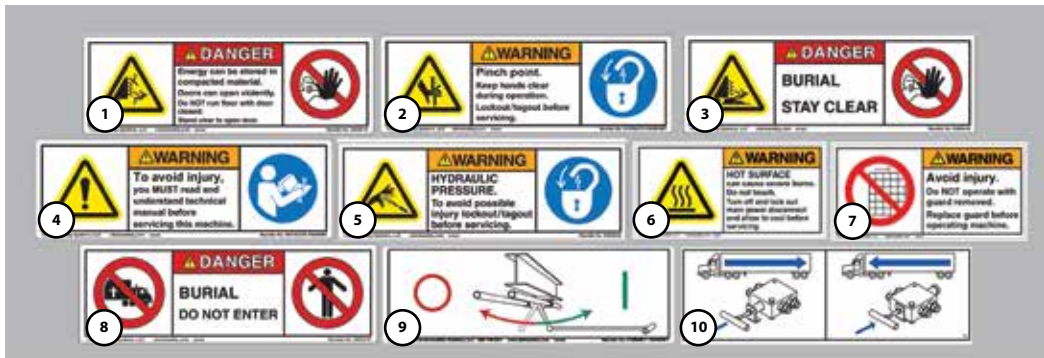

\*3. Decal should be applied so it is completely visible with the doors open.

RFII DECAL KIT: #84804002	SIZE:	QTY:	ITEM #
1. Danger/Stored Energy (English)	6" x 2"	1	8480410 1
2. Pinch Point (English)	6" x 2"	4	84804124
3. Danger/Burial (English)	6" x 2"	2	84804100
4. Read Manual (English)	6" x 2"	2	84804123
5. Hydraulic Pressure (English)	6" x 2"	2	84804128
6. Warning Hot Surface (English)	4" x 2"	2	84804127
7. Guard (English)	4" x 2"	1	84804126
8. Danger/Burial Do Not Enter (English)	6" x 2"	1	84804132
9. Ball Valve	6" x 2"	1	84804129
10. Control Valve (LH)	6" x 2"	1	84804131
N.A. Placement Instruction Guide	N.A.	1	84804001

### Safe Start-Up/Shutdown

1. Set parking brake on truck and trailer.
2. Open trailer doors fully and secure doors with provided chains or loop rings. **ALWAYS** have doors fully open! **Do not, under any circumstances, engage the Power Take Off / Pump (P.T.O.) or WALKING FLOOR® unloader with the doors of the trailer closed. Do not go under trailer body or enter the trailer while the system is in operation, nor allow anyone to stand or move through the area where the load is being discharged.**
3. Close the ball valve by pulling the handle outward.
4. Connect hydraulic hoses to power unit (truck).
5. Engage P.T.O. and set to unload RPM.
6. While unloading, NEVER leave truck and trailer unattended!
7. After unloading has been completed, stop the floor with all slats in the forward position by placing the ball valve in the open position.
8. Disengage P.T.O.
9. Close doors and secure hydraulic hoses.
10. If a problem should arise while unloading, promptly do one of the following:
  - a. Disengage P.T.O. system.
  - b. Open ball valve.

### CAUTION

**Observations may be made while system is operating for troubleshooting purposes, but NEVER touch any moving part or attempt to make any adjustments to the system with the Power Take Off/Pumping system engaged or the WALKING FLOOR® unloader operating. Do not attempt to make adjustments or repairs without consulting with a trained service technician from your company or contact KEITH Mfg. Co. at 1-800-547-6161 or via email at [techdept@keithwalkingfloor.com](mailto:techdept@keithwalkingfloor.com) for further assistance.**

## Driver Check List

Pre-trip Check: Trailer Empty

1. Inspect hoses and connectors for damage and contamination. Clean all dirt and water from connectors before hooking up.
2. Inspect drive unit for leaking fittings or hoses and visible damage.
3. Open trailer door and inspect flooring for impact damage.
4. Inspect flooring at the rear of the trailer for loose or bent slats that may have popped up.
5. Hook up hydraulic connectors and operate the floor. Inspect for leaks while operating. Engage and disengage ball valve to check for proper operation. Check control valve for proper operation (Forward, reverse).
6. If problems are found, report them to the maintenance shop as soon as possible.
7. Secure trailer door and proceed.

**Note:** If trailer is loaded, perform steps 3 and 4 after unloading.

**As the driver, you will see damage or operational problems before anyone else. Please report it as soon as possible.**

## Operation of your KEITH® Running Floor II® Unloader

### UNLOADING

1. Before beginning to unload, make sure the trailer door(s) is/are open.
2. To unload with your KEITH® Running Floor II® system, pull the control valve handle all the way out. (See Diagram A.)
3. Make sure that the ball valve, located between the pressure and return lines, is in the closed (run) position. (See Diagram B.) This ball valve is used for the emergency shut-off.
4. Engage the P.T.O., then bring the tractor engine up to the predetermined unloading RPM. Your trailer floor should now be operating.
5. To stop the floor at any time during the loading or unloading process, switch the ball valve to the open (Stop) position. (See Diagram B.)

### LOADING

1. To load with your bi-directional KEITH® Running Floor II® system, simply turn the control valve handle parallel to the ground and push it all the way in. (See Diagram A.) Then follow instructions 3, 4 and 5 listed above.

### !!Note!!

**Make sure the trailer door(s) is/are open BEFORE starting the floor or the trailer door(s) may be damaged. The nose of the trailer may also be damaged by the load force when loading.**

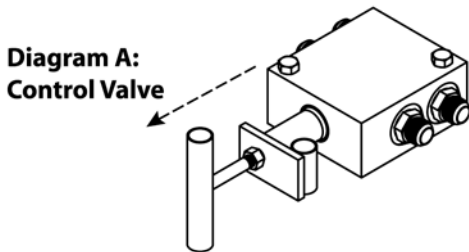

**PULL TO UNLOAD**  
Handle Pulled Completely Out

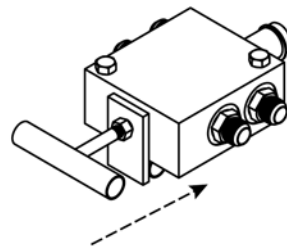

**PUSH TO LOAD**  
Handle Pushed Completely In

Diagram B:  
Ball Valve

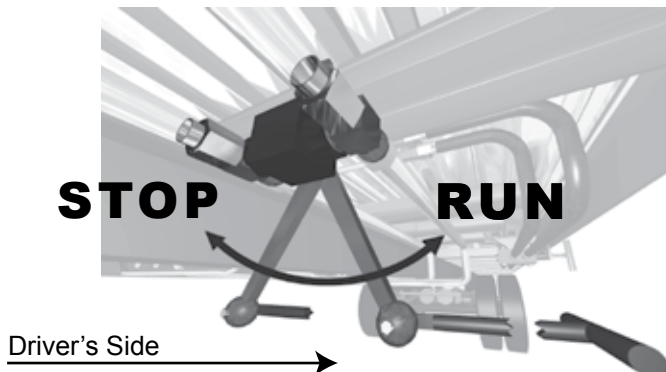

**Component Location Guide** *(View from underneath the trailer).*

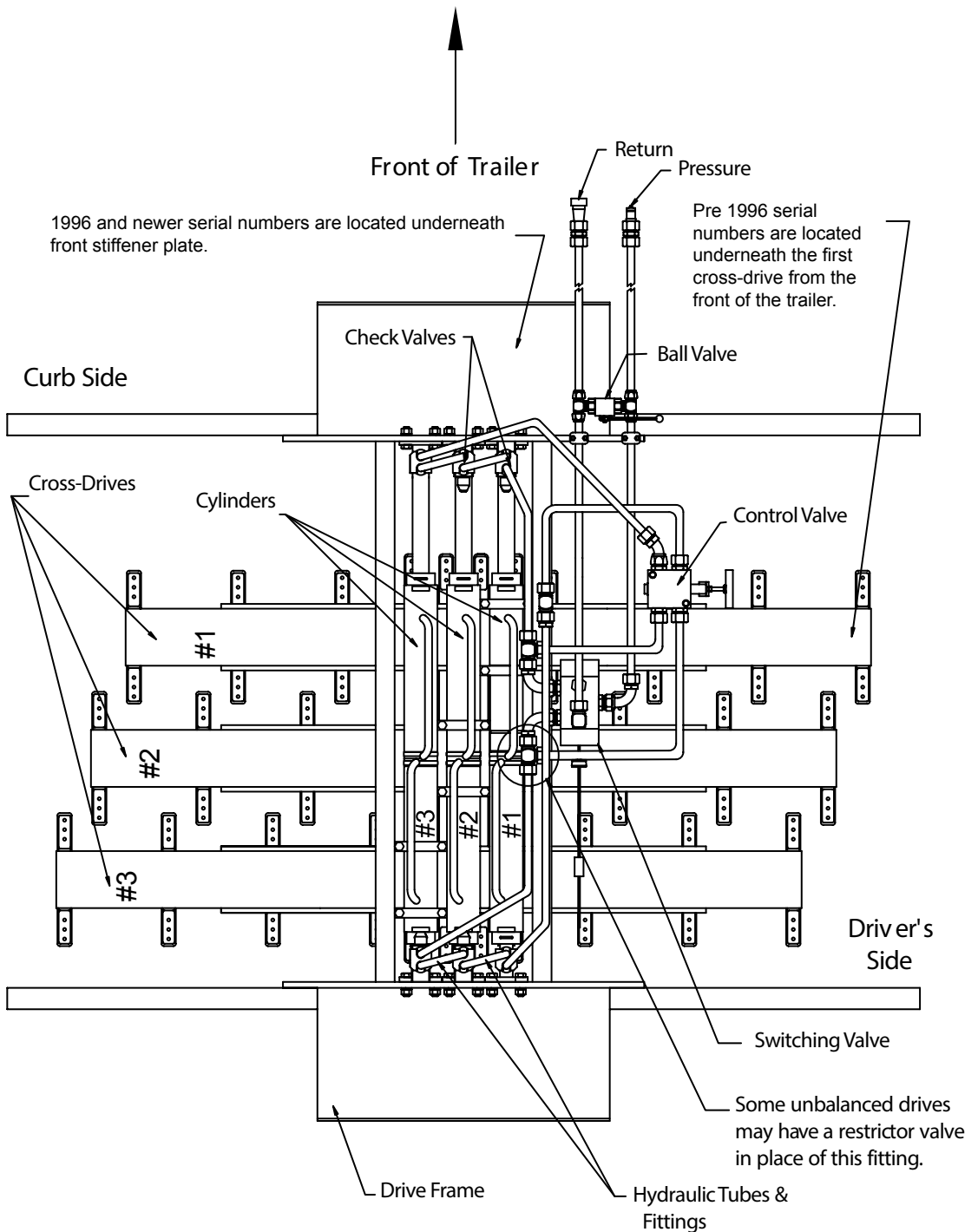

## How It Works

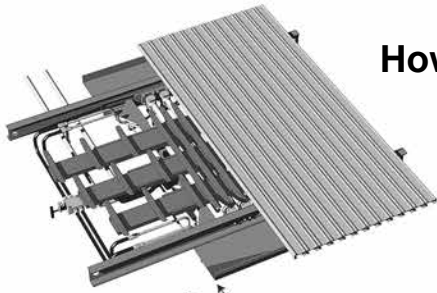

### Initial State

All slats/planks at discharge end.

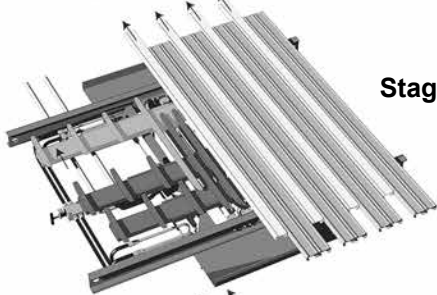

### Stage 1

The first group of slats/planks moves under the load.

**Load does not move.**

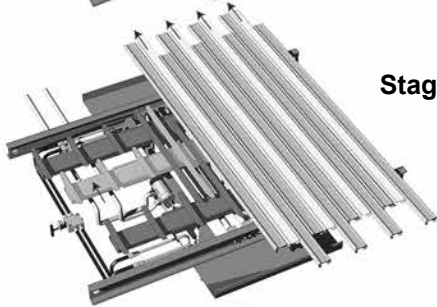

### Stage 2

The second group of slats/planks moves under the load.

**Load does not move.**

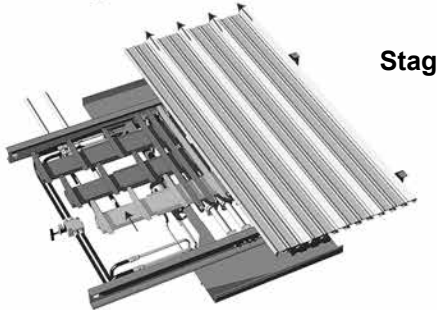

### Stage 3

The final group of slats/planks moves under the load.

**Load does not move.**

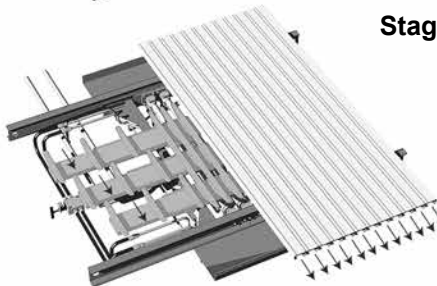

### Stage 4

All slats/planks move together.

**Load moves toward the discharge end.**

(Stages 1, 2 & 3 require more pressure than stage 4.)

## Running Floor II® Drive How The System Works

### Unload Cycle Description-

#### Phase One:

Cylinder (#1), the drivers' side cylinder, travels toward the front of the trailer. As it reaches the end, the #1 check valve is opened. This releases blocked oil, allowing cylinder (#2), the center cylinder, to travel.

#### Phase Two:

Cylinder (#2) travels toward the front of the trailer. The #2 check valve is opened, releasing oil and allowing cylinder (#3), the curb side cylinder, to travel.

#### Phase Three:

Cylinder (#3) travels toward the front of the trailer. As it reaches the end of its travel, a loop on the #3 cross-drive pushes the threaded rod connected to the switching valve. The threaded rod is pushed into the switching valve, changing the hydraulic oil flow direction.

#### Phase Four:

As all three cylinders travel toward the rear of the trailer, the load is transferred to the discharge end. When all cylinders have reached their maximum stroke, the loop on the #1 cross-drive pushes the threaded rod connected to the switching valve. The threaded rod is pushed into the switching valve, changing the flow of oil and starting the cycle over.

## Plumbing Diagram

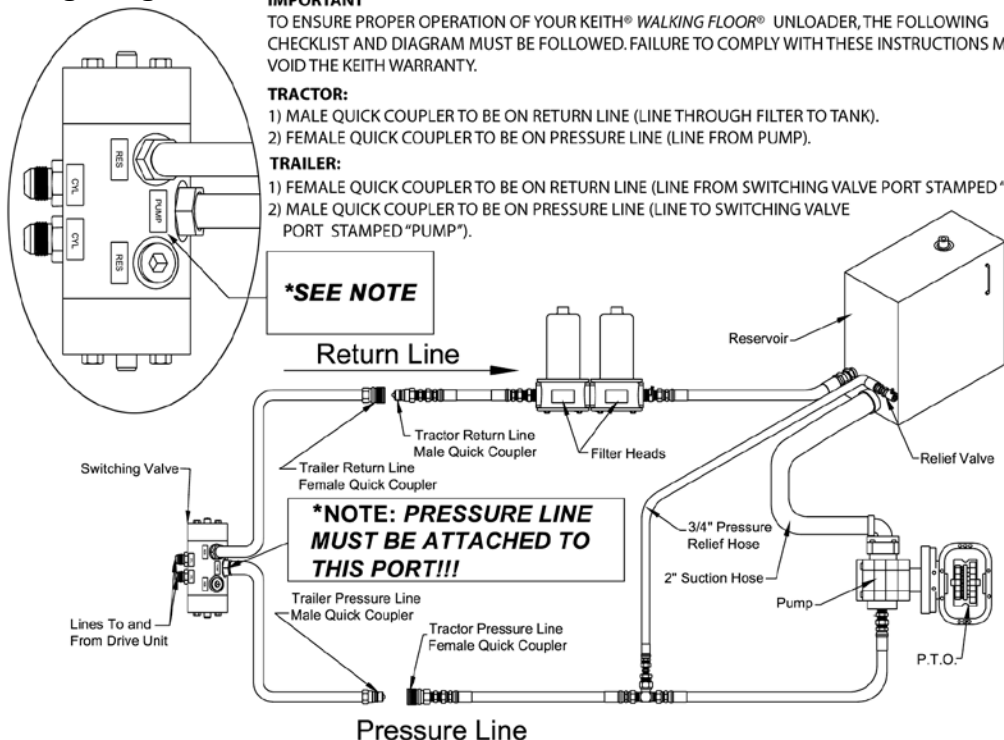

**\*NOTE: The pressure and return lines must attach to their proper ports on the switching valve. If you have any questions or problems, call KEITH Mfg. Co. at 800-547-6161.**

## Start-Up Check List for the KEITH® RUNNING FLOOR II® System

Before starting your new KEITH® RUNNING FLOOR II® unloader, a quick start-up check should be made.

1. Is your entire system plumbed to the plumbing diagram?
2. \*Pump: Will it pump 30-35 GPM at 3000 PSI?
3. \*Relief Valve: Is it set at 2800-3000 PSI?
4. Oil: Have you filled the reservoir?
5. Power Take Off: Is the P.T.O. engaged?
6. Quick Disconnects: Are they the same size and type? Are they completely engaged?
7. Ball Valve: Is the ball valve on the drive unit closed?
8. Is the pressure line on the trailer attached to the pressure line on the tractor and the return line on the trailer attached to the return line on the tractor?

\*If the information about your pump and relief valve is not known, a pressure/flow check will help determine this information. Be sure that your entire wet kit system meets the requirements of the hydraulic wet kit specifications in this manual.

Wet Kit Diagram

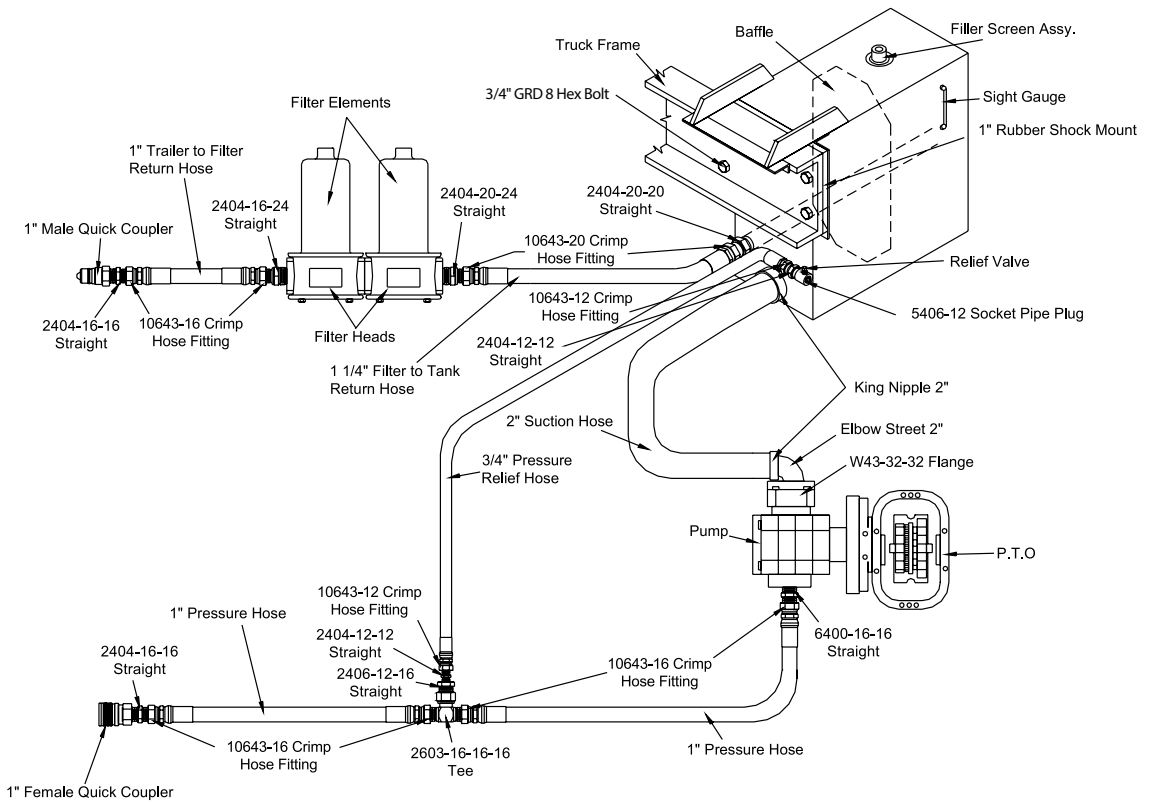

Floor Speed in Relation to Engine RPM

Example: With a P.T.O. output shaft speed rated at 118% of engine RPM, using a P51, P051, P5100 or PL27 type pump with dowelled housing and a 2 1/2" gear. The engine RPM in relation to the floor movement is as follows.

Engine RPM	Pump Output	Speed Ft/ Minute*	Unloading Time 45 ft Trailer
950 RPM	30 g/minute	8.2 ft/minute	7-8 minutes
1430 RPM	45 g/minute	12.5 ft/minute	5-6 minutes
1900 RPM	60 g/minute	16.4 ft/minute	3-4 minutes

Above specifications are for RUNNING FLOOR II® drive unit with 3.0" bore cylinders. These are approximate feet per minute only and should be used strictly as a guide.

**Note: KEITH Mfg. Co. recommends installing KEITH® RUNNING FLOOR II® drive units incorporating 3.5 inch cylinders for use in all semi-trailers with three or more axles.**

### Wet Kit Information

<b>Transmission:</b>	This wet kit is designed to be used with most transmissions. Power Take Off (P.T.O.) specifications may vary with some transmissions. Please check with your supplier for specific applications.
<b>Oil:</b>	Chevron AW46 hydraulic oil or equivalent. (Lower viscosity in colder climates).
<b>P.T.O.:</b>	Chelsea series 442/489 or Muncie CS6/CS8 Power Take Off unit, rated at approximately 118-125% of engine RPM. (Electronic Overspeed Control is highly recommended).
<b>Pump:</b>	P51, P051, P5100 or PL27 type pump with dowelled housing and a 2 1/2" gear. (Recommend a 2" four bolt, suction port).
<b>Filter:</b>	Filter should be 10 to 25 micron on the return line. Filter should be a double element Zinga or equivalent. Filter head #DF-15-25. MF 2215-25-0-2-0. Filter element #LE-10 or LE-25. (The filter element should be changed after 6 hours initially, and then every 6 months thereafter. This may vary with the operating environment).
<b>Hydraulic Reservoir:</b>	Should hold approximately 1 gallon of oil for every gallon per minute you plan to pump, i.e. 40 GPM = 40 gallon reservoir. Reservoir should hold a minimum of 40 gallons of oil.
<b>Suction Line:</b>	Suction line from the tank to the pump should be no more than 5' in length and a minimum of 2" inside diameter. Example: SAE-100R4. (This type of line has a spiral wire to keep the hose from collapsing under suction).
<b>Pressure Line:</b>	Hose from truck to trailer should be 1" 16 SAE-100R2.
<b>Return Line:</b>	Hose from <b>trailer to filter</b> should be 1" 16 SAE-100R1. Hose from <b>filter to tank</b> should be 1¼" 20 SAE-100R1.
<b>*Pressure Relief Valve:</b>	High quality valve, with the ability to relieve full pump flow at 3000 PSI.

**\*Note: It is critical that the relief valve is set at no less than 2800 PSI and no more than 3000 PSI.**

## Switching Valve Adjustment

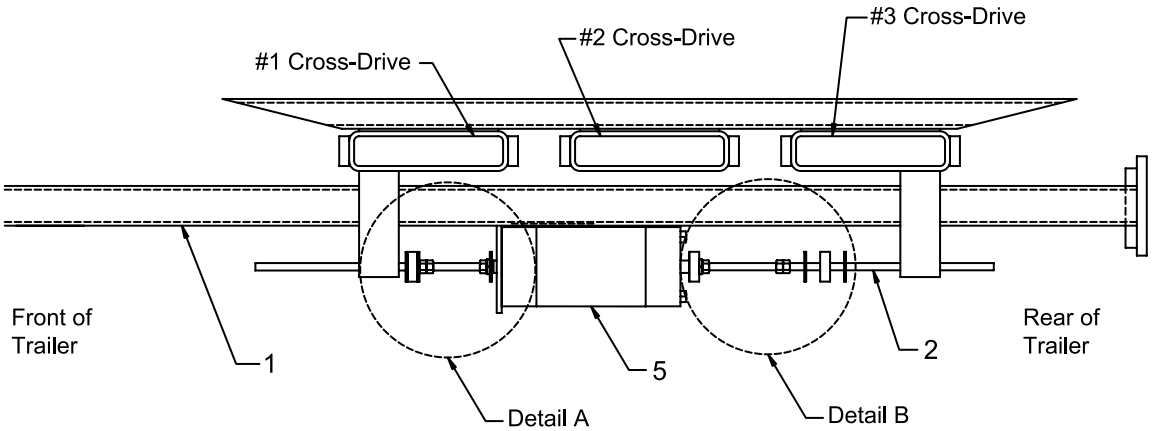

**NOTE:** This view is from the driver's side of the trailer. All cylinders are shown to the rear of the trailer.

1. 2" x 2" Steel Tube
2. 3/8" Threaded Rod (typ. 2 pcs)
3. 3/8" Nuts
4. 3/8" Flat Washers

5. Switching Valve
6. 3/8" Lock Washer
7. Switching Valve Grommet
8. Switching Valve Limit Cap

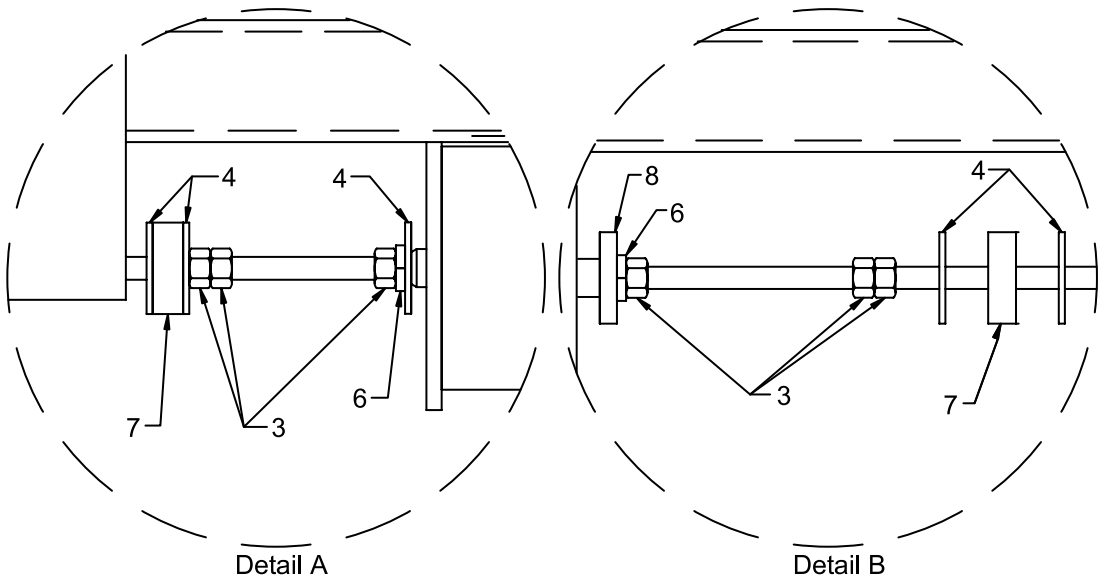

## Switching Valve Adjustment

Tools needed: (2) 9/16 inch open-end wrenches.

Most switching valves are incorrectly replaced because they are out of adjustment.

Always adjust the switching valve as described below.

1.	<p><b>Use the ball valve to stop the drive unit.</b> The ball valve is located toward the front of the drive unit, in front of the hydraulic cylinders. Move the ball valve handle toward the center of the trailer, which will allow the hydraulic oil to by-pass the drive unit.</p>
2.	<p><b>Loosen the 3/8" jam nuts located on the threaded rods on each end of the switching valve.</b> On each threaded rod there are two flat washers and a rubber grommet. The 3/8" jam nuts are located between the switching valve and the washers. After loosening the nuts, adjust them toward the switching valve. Doing this will throw the switching valve out of adjustment. Repeat the process at the other end of the switching valve.</p>
3.	<p><b>Start the truck engine and engage the P.T.O.</b> Let the clutch out slowly. Pull the ball valve handle toward the driver's side. The drive unit will move to the load or unload direction. The system will lock up and be under high pressure when the cylinders reach the end of the stroke. Immediately push the ball valve handle toward the center of the trailer. This will allow the hydraulic oil to bypass the system. At this point, the cylinders will be at maximum stroke.</p>
4.	<p><b>Disengage P.T.O.</b></p>
5.	<p><b>Push the threaded rod in the direction that the cylinders are bottomed.</b> Slide the washers and rubber grommet out toward the loop on the cross drive. Turn the 3/8" jam nuts out until they are tight against the washers. Then turn the first nut one extra turn. Bring the second nut up to the first nut and tighten the two together, setting the jam nuts.</p>
6.	<p><b>Engage P.T.O.</b></p>
7.	<p><b>Move the ball valve handle slowly, causing the hydraulic cylinders to travel to the opposite direction.</b> Let the cylinders travel until they lock up. Then push the ball valve handle to the center.</p>
8.	<p><b>Disengage P.T.O.</b></p>
9.	<p><b>Push the threaded rod in the direction that the cylinders are bottomed. Slide the washers and rubber grommet out toward the loop on the other cross drive.</b> Turn the 3/8" jam nuts out until they are tight against the washers. Then turn the first nut one extra turn. Bring the second nut up to the first nut and tighten the two together, setting the jam nuts.</p>
10.	<p><b>The switching valve adjustment is completed.</b></p>

### Switching Valve Troubleshooting

<b>Problem:</b>	Cylinder (#1) moves toward the front of the trailer. Cylinder (#2) moves toward the front of the trailer. Cylinder (#3) moves toward the front of the trailer; then the system stops.
<b>Cause:</b>	The threaded rod nuts on the discharge end of the switching valve are not adjusted correctly.
<b>Solution:</b>	Break the two nuts apart and adjust toward the rear of the trailer.
<b>Problem:</b>	All three cylinders move toward the rear of the trailer; then the system stops.
<b>Cause:</b>	The threaded rod nuts on the forward end of the switching valve are not adjusted correctly, or there is not enough hydraulic pressure. (See *Note.)
<b>Solution:</b>	Break the two nuts apart and adjust toward the front of the trailer.
<b>Problem:</b>	Floor runs fine empty or with a light load, but will not cycle with a heavy load.
<b>Cause:</b>	The nuts on the threaded rod are slightly out of adjustment, or there is not enough hydraulic pressure. (See *Note.)
<b>Solution:</b>	Break the two nuts apart and adjust them away from the Switching Valve body.
<b>Problem:</b>	After installing a new switching valve, the floor will not move.
<b>Solution:</b>	The switching valve is out of adjustment or the new-style switching valve will not work if the pressure and return lines are backward.
<b>Problem:</b>	The cylinders cycle to the front correctly— cylinder (#1), followed by (#2) then (#3). Then, as all three cylinders begin to move toward the rear, (#3) cross-drive and cylinder move two to three inches back and forth.
<b>Solution:</b>	The switching valve loop on the cross-drive is bent and binding against the threaded rod. Bend the loop away from the threaded rod so that it will enable the threaded rod to travel freely.

**\*Note:** (If floor stops in the full rear position and the switching valve has switched, you may not have enough oil pressure. Less pressure is required to move the load than to pull the slats 1/3 at a time under the load.)

## Check Valve Troubleshooting

The exterior check valve is designed to vent oil from the return side of the cylinder. It does not direct pressurized oil into the cylinder.

### Unloading

<b>Problem:</b>	Cylinders (#1) and (#2) extend together toward the front of trailer.
Cause:	The check valve at the forward end of cylinder (#1) has malfunctioned.
Solution:	Rebuild or replace the check valve.
<b>Problem:</b>	Cylinders (#2) and (#3) extend together toward the front of trailer.
Cause:	The check valve at the forward end of cylinder (#2) has malfunctioned.
Solution:	Rebuild or replace the check valve.
<b>Problem:</b>	All three cylinders extend together toward the front of trailer.
Cause:	The check valves at the forward end of cylinders (#1) and (#2) have malfunctioned (Unlikely) or oil is leaking in the control valve and “floating” the check valves.
Solution:	Rebuild or replace the check valves or control valve.

### Loading

<b>Problem:</b>	Cylinders (#2) and (#3) extend together toward the rear of trailer.
Cause:	The check valve at the rear end of cylinder (#3) has malfunctioned.
Solution:	Rebuild or replace the check valve.
<b>Problem:</b>	Cylinders (#1) and (#2) extend together toward the rear of trailer.
Cause:	The check valve at the rear end of cylinder (#2) has malfunctioned.
Solution:	Rebuild or replace the check valve.
<b>Problem:</b>	All three cylinders extend together toward the rear of trailer.
Cause:	The check valves at the rear end of cylinders (#2) and (#3) have malfunctioned (Unlikely) or oil is leaking in the control valve and “floating” the check valves.
Solution:	Rebuild or replace the check valves or control valve.

See “Replacing a Check Valve” Page 18

The check valves at the rear of the cylinders (discharge end) do nothing when you are unloading. The check valves at the rear are used for loading only.

**Note: When empty, some trailers will cycle in sequence forward 1-2-3, then back 3-2-1, (Instead of all slats moving back together). This is not a malfunction; no repairs are needed. When a load is put on a trailer, the drag will cause the floor to sequence properly.**

## Replacing a Check Valve

Replacing a KEITH® RUNNING FLOOR II® external check valve is a simple procedure. The tools required to do this are:

- (1) 1/2" socket
- (1) 6" or 12" extension
- (1) ratchet

## DISASSEMBLY

Before removing any bolts, run the cylinder away from the check valve in order to free it. Next remove the four 5/16" x 5-1/2" bolts and tube clamp. Loosen the other end of the tubes and remove the check valve.

## ASSEMBLY

First, make sure all of the surfaces are clean and the O-rings are in the proper places. Put the new check valve in place making sure it seats flat on the rod end. Put the tube clamp back on and put the 5/16" x 5-1/2" bolts back in. Make sure the tubes fit snugly back into the tube clamp and tighten the 5/16" x 5-1/2" bolts down. Tighten the other ends of the cylinder cross-over tubes and run the floor to check for leaks.

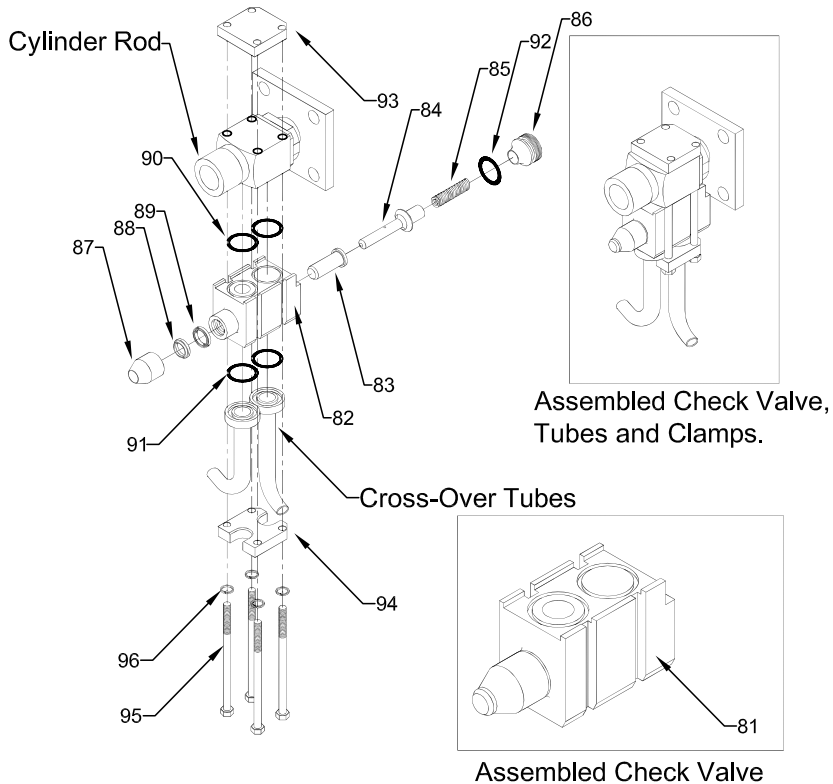

## Control Valve, Ball Valve Troubleshooting

### Control Valve

The control valve controls the direction of material movement (Load or unload).

Hydraulic oil is directed through the valve by moving the valve handle in or out. When the handle is pulled out, the *WALKING FLOOR*® system unloads. The oil is flowing through the outside hydraulic lines and blocked from flowing through the inside lines. When the valve handle is pushed in, the floor loads. Oil flows through the inside lines and is blocked from flowing through the outside lines.

If the valve spool becomes worn or scored, a hydraulic bypass will be created and the oil will get hot. Isolate the valve by pulling the handle out. Remove the two inside hydraulic lines, cap the valve and plug the lines. If the drive unit runs without the oil getting hot, the valve needs to be changed.

### Ball Valve

**Note: The ball valve is intended to use as an emergency shut off!**

The ball valve will start or stop the floor.

The ball valve is open when the handle is pushed in. Oil is allowed to flow through the ball valve and back to the tank. When the handle is pulled out, the valve is closed. Oil flows to the drive unit. If the ball valve gets hot to the touch, the inner seals are worn. This can occur from using the wrong hydraulic pump, bad quick couplers, or from any problem that causes a hydraulic bypass. The ball valve has two Teflon® cup seals; one located on each side of the ball port. If these seals get hot, they will break down. This causes hydraulic oil to slip by, creating heat. You may not be able to move the load because of loss of pressure. The ball valve needs to be rebuilt or replaced.

## Hydraulic Cylinders Troubleshooting

### Hydraulic Cylinders

Hydraulic cylinders are usually damaged from heat or foreign materials (Causing seals, wear sleeve, etc. to break down).

The way to check the cylinders is to use an infrared heat detector or by touching each end of the cylinder barrel. If you find one end or both that are warmer than the other cylinders, it usually indicates which cylinder is damaged.

**Caution: Never touch any component part of the Running Floor II® drive or perform this check while the drive unit is operating or P.T.O. engaged. Always shut the system down before performing maintenance.**

<b>Problem:</b>	Cylinder (#1) moves fine, (#2) moves fine, (#3) will start to move then suddenly stop. (#3) will then travel four to five inches and move fast.
<b>Solution:</b>	The cylinder (#3) clamp is too tight. This could happen on any one of the three cylinders. Re-torque to 135 ft-lbs.
<b>Problem:</b>	After (#1) cylinder, the drivers' side cylinder, has been changed, the system is operated. (#1) moves to the check valve and opens the check valve. (#2) moves forward, but stops before it reaches the check valve and the hydraulics are at high pressure.
<b>Solution:</b>	Cylinder (#1) was not installed in the correct position. This is not allowing (#2) to travel the distance needed to open the (#2) check valve. The correct measurements for the Running Floor II® 3.0" and 3.5" cylinders are as follows: Cylinder (#1) from end of barrel to front threaded clamp = 1 ½" Cylinder (#3) from end of barrel to front threaded clamp = 1 ½" Cylinder (#2) is centered between (#1) and (#3) Do not measure from the cylinder head.
<b>Problem:</b>	In the Unload mode: As all three cylinders travel toward the rear of the trailer, cylinder (#3) moves faster than (#1) or (#2).
<b>Solution:</b>	There is not enough restriction on cylinder (#3). It is recommended to install an RV-2 valve, a restrictor valve, between the switching valve and cylinder or a check valve with a heavier internal spring.

## Repairing Cylinders

To repair or replace the cylinder, you have to remove the check valves on each end of the cylinder that will be removed. Loosen the bolts from the check valve beside the one being removed. This is so you can swing the hydraulic cross-over tubes out of the way. There will be a total of twelve 5/8" bolts. Each end of the cylinder will have four and there will be four bolts from the cross-drive. Leave one bolt on each end of the cylinder to hold it in place, but loosen it so that it is almost out. Have one person on each end of the cylinder remove the bolt and let the cylinder down. Use the same method to put the cylinder back in.

Before installing the new cylinder, be sure to check the threaded pad on the cylinder and upper clamp on the cross-drive for damage. If the threads are damaged, replace with a new barrel or cross-drive, if necessary. The threaded pads must mate perfectly and the barrel clamps must be tightened properly to prevent slippage. (135 ft-lbs).

On cylinder (#1) and cylinder (#3), at the end closest to the cross-drive from the end of the barrel to the cross-drive upper clamp, the measurement is 1-1/2". Cylinder (#2) is located in the center of the upper clamp.

**Note:** In all Running Floor II® units, cylinder (#1) is located on the driver's side of the trailer. It is also the first cross-drive that moves to the front of the trailer. We do have different firing on some of our drives. Always check this first, as well as check if all three cylinders are the same.

### **Rule of Thumb:**

If you have a cylinder leaking due to heat, usually all three cylinders will need to be (Or should be) repaired or replaced.

**KEITH® Running Floor II® Oil Flow Diagram (Unloading Cycle)**

Pressure   
  Return  
 Blocked   
  Standing Oil  
 Return Oil

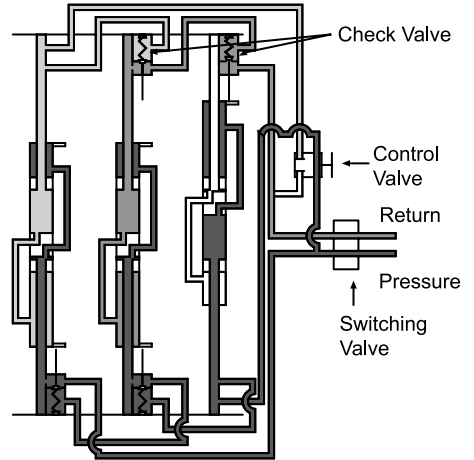
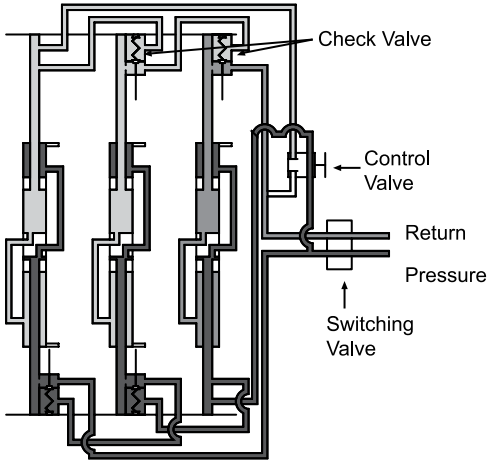

**Phase 1**  
 Pressure in the rear of all cylinders as shown in .  
 Open to return.  
 Blocked by check valves.  
**Note: Phase 1 requires more pressure than phase 4.**

**Phase 2**  
 The #1 cylinder completes its full stroke, opening the check valve and allowing the oil in the #2 cylinder to escape as shown in . ( Shows standing oil.)  
 Pressure still in rear of all cylinders as shown in .  
 Blocked by check valve.  
**Note: Phase 2 requires more pressure than phase 1.**

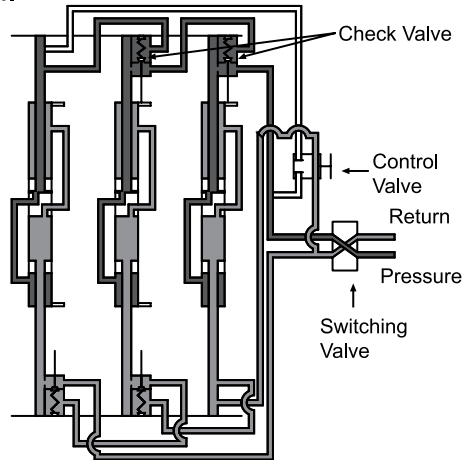
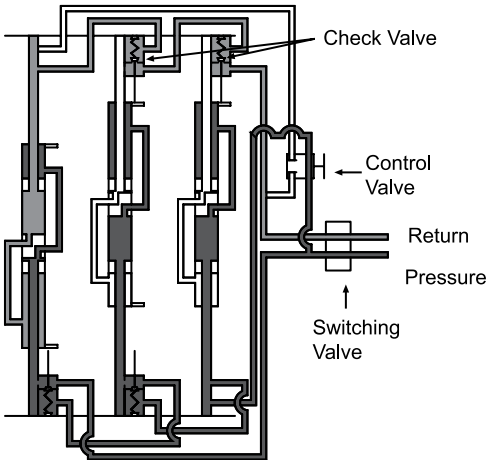

**Phase 3**  
 The #2 cylinder completes its full stroke, opening the check valve and allowing the oil in the #3 cylinder to escape to return as shown in . ( Shows standing oil.)  
 Pressure still in rear of all cylinders as shown in .  
**Note: Phase 3 requires more pressure than phase 2.**

**Phase 4**  
 When the #3 cylinder completes its stroke, the pressure and return are switched by the switching valve, transferring the pressure to the front of all cylinders as shown in . All cylinders are open to return as shown in . All cylinders move to rear of trailer together, moving the load.  
**Note: Phase 4 requires less pressure than phases 1, 2, or 3.**

## Suggested Preventive Maintenance Schedule

### New Trailer:

1. Check torque on barrel clamp bolts before first load and after the first week of operation. 5/8" bolts/135-lbs.
2. Check torque on floor bolts after one week of operation. 5/16" bolts/22-lbs.  
3/8" bolts/42-lbs.  
5/8" bolts/180-lbs 9 Slat Kwik Klamp .  
5/8" bolts/150-lbs 24 Slat Kwik Klamp.  
3/8" bolts/45-lbs Integrated V Slat.
3. Visually check for hydraulic leaks. Check the cylinder area, around the pressure and return hydraulic tubes, around the switching valve, check valves, and the quick disconnect. If leaks are found, retighten the fittings.

### Used Trailer:

1. Visually check for hydraulic leaks.
2. Visually inspect the cross-drive support bearing for excessive wear. Replace if needed.
3. Visually inspect the cross-drive tubes and drive shoes for damage. Replace or repair as needed.
4. Inspect flooring for loose slats or bent slats that may have popped up due to impact damage.
5. Visually inspect for excessive wear of the floor bearings over each vehicle tire. Replace as needed.
6. The type of material being transported will affect the timing of the following procedure. A general guide for slat rotation or replacement is after approximately 3,000 loads. Check for wear on the rear of the slats and if they are worn more than 3/4" of the original thickness, it is suggested to remove and rotate the flooring end-for-end for extended life.
7. Pressure wash the drive unit, sub-deck and slats at least twice per year. Once per quarter, if possible.
8. Cycle the system and observe for proper operation in the load and unload modes.
9. Check the torque of the barrel clamp and floor bolts. See torque chart Page 42.

**Note:** The hydraulic wet kit must meet KEITH Mfg. Co. requirements and must be properly maintained to avoid damaging the *WALKING FLOOR*® system.

### Drive Frame & Related Components

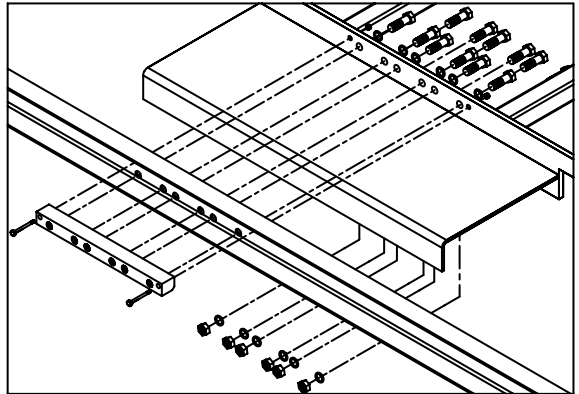
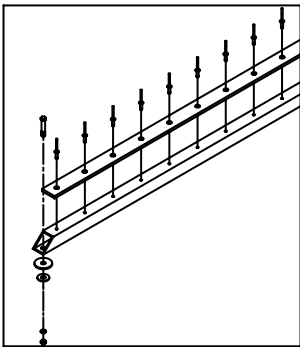
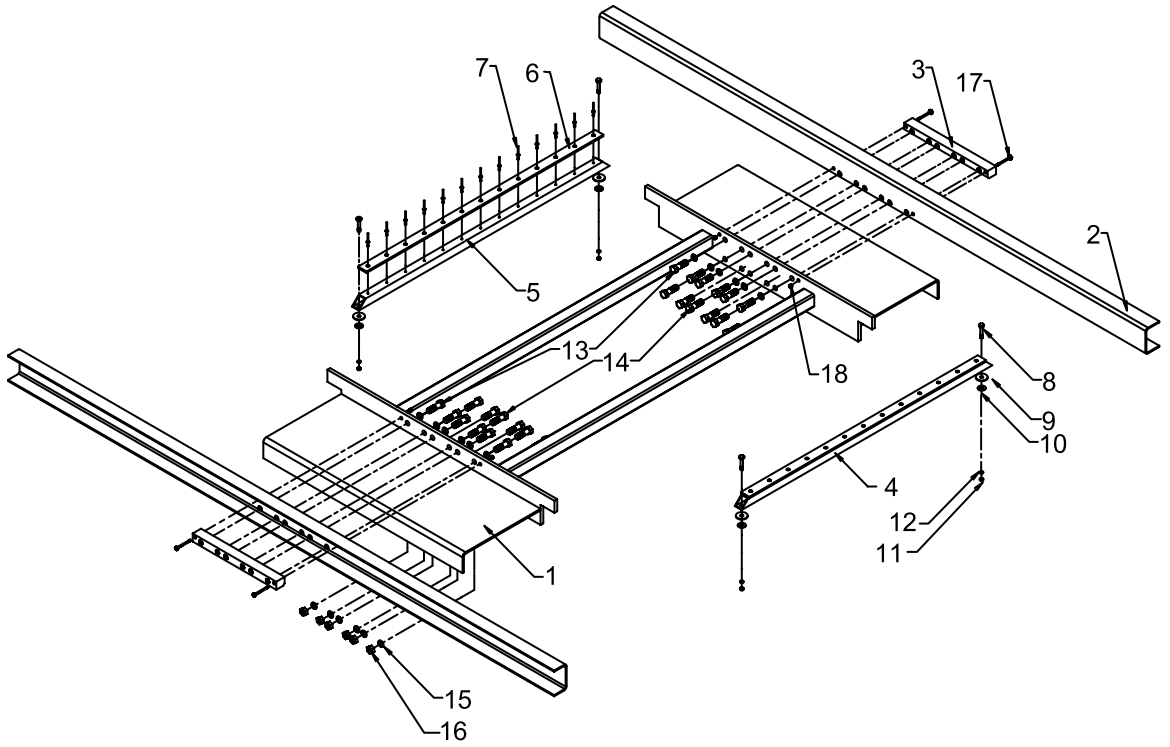

### Drive Frame & Related Components

ID #	QUANTITY	DESCRIPTION	PART NUMBER
<b>Drive Frame &amp; Related Components</b>			
-	1	<b>Drive Frame Assembly</b>	-
-	-	Includes items 1-18	-
1 <sup>(1)</sup>	1	Drive Frame Steel	-
2 <sup>(1)(2)</sup>	2	Channel Formed 4"x2 1/4"x3/16"	w/frame
3 <sup>(1)</sup>	2	Nut Bar Threaded 4.5" Cylinder Centers	04175101
3 <sup>(1)</sup>	2	Nut Bar Threaded 5.0" Cylinder Centers	01173101
4 <sup>(1)</sup>	2	<b>Bearing 1/4" Cross-Drive Support Assembly</b>	<b>03467801</b>
-	-	Includes items 5-7	-
5 <sup>(1)</sup>	1	Bearing Cross-Drive Support Tube	03467701
6 <sup>(1)</sup>	1	Bearing Cross-Drive Support 1/4" UHMW	03453901
7	13	Rivet 3/16"x1/2"	86528150
8	4	Bolt Hex GR5 3/8"x1 1/4"	86438000
9	4	Washer Large OD 3/8"	86553500
10	4	Washer Flat 3/8"	86554000
11	4	Nut Hex 3/8"	86628500
12	4	Washer Lock 3/8"	86555000
13	12	Bolt Hex GR8 5/8"x2 3/4", (3.0" Cyl)	86466500
13	12	Bolt Hex GR8 5/8"x3", (3.5" Cyl)	86467000
14	12	Bolt Hex GR8 5/8"x2", (3.0" Cyl)	86464500
14	12	Bolt Hex GR8 5/8"x2 1/4", (3.5" Cyl)	86465500
15	24	Washer Lock 5/8"	86559000
16	24	Nut Hex 5/8"	86632000
17	4	Bolt Hex GR5 1/4"x2 1/4", (3.0" Cyl)	86419500
17	4	Bolt Hex GR5 1/4"x2 1/2", (3.5" Cyl)	86420000
18	4	Nut Hex Nylock 1/4"	86626000

(1) Part numbers and descriptions vary based on the drive configuration and application.

(2) Formed Channels are included with frame. In many applications they are non-removable.

### Cross-Drive Assembly

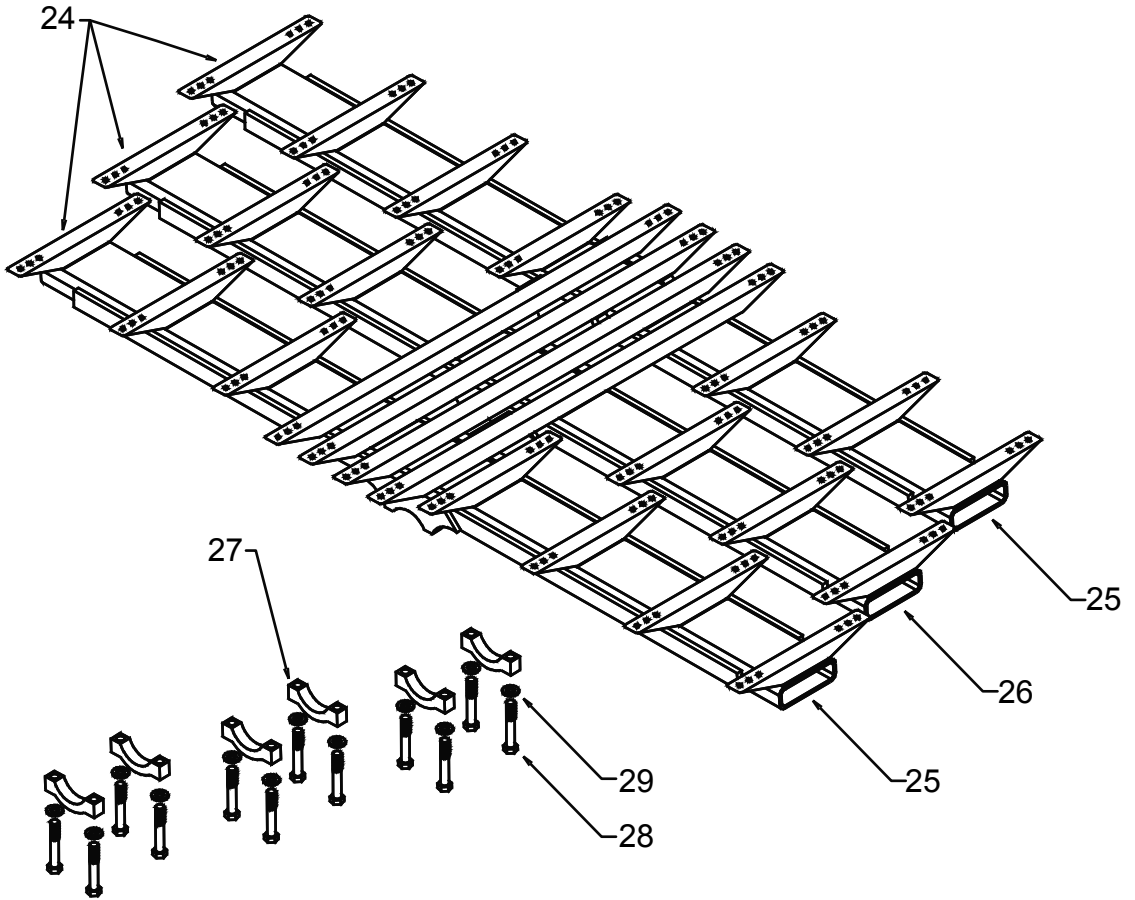

## Cross-Drive Assembly

### Parts List

ID#	QUANTITY	DESCRIPTION	PART NUMBER
<b>Cross-Drive Assembly</b>			
24 <sup>(1)</sup>	1	<b>Cross-Drive 24 Slat 3.0" 4.5" Cylinder Center Set</b>	<b>02535501</b>
24 <sup>(1)</sup>	1	<b>Cross-Drive 24 Slat 3.5" 5.0" Cylinder Center Set</b>	<b>02520501</b>
-	-	Includes items 25 & 26	-
25 <sup>(1)</sup>	2	Cross-Drive 24 Slat 3.0" 4.5" Cylinder Center #1 & #3	02535502
25 <sup>(1)</sup>	2	Cross-Drive 24 Slat 3.5" 5.0" Cylinder Center #1 & #3	02520502
26 <sup>(1)</sup>	1	Cross-Drive 24 Slat 3.0" 4.5" Cylinder Center #2	02535503
26 <sup>(1)</sup>	1	Cross-Drive 24 Slat 3.5" 5.0" Cylinder Center #2	02520503
27	6	Clamp 3.0" Lower Cross-Drive	03910501
27	6	Clamp 3.5" Lower Cross-Drive	03910601
28	12	Bolt Hex Patchloc GR8 5/8"x4", (3.0" Cyl)	86470010
28	12	Bolt Hex Patchloc GR8 5/8"x4 1/2", (3.5" Cyl)	86470510
29	12	Washer, Nord Lock 5/8"	86559090

(1) Part numbers and descriptions vary based on drive configuration

## Cylinder Assembly

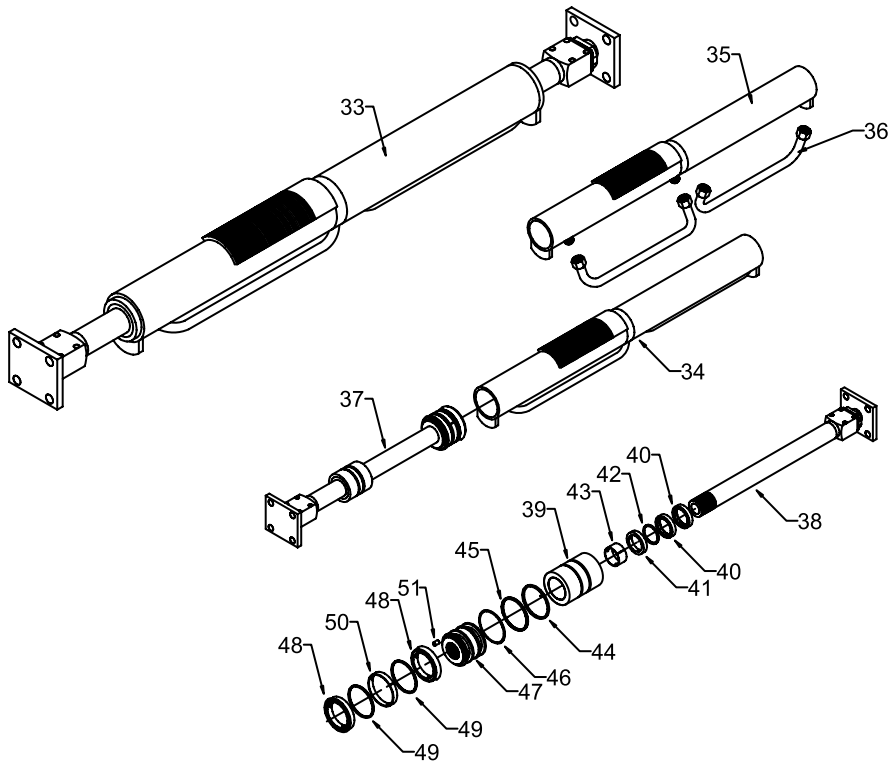

ID #	QUANTITY	DESCRIPTION	PART NUMBER
33	1	<b>Cylinder 3.0" Assembly</b>	<b>04567901</b>
33	1	<b>Cylinder 3.5" Assembly</b>	<b>04568001</b>
-	-	Includes items 34-51	
34	1	<b>Barrel Assembly 3.0" Cylinder</b>	<b>04560901</b>
34	1	<b>Barrel Assembly 3.5" Cylinder</b>	<b>04561001</b>
-	-	Includes items 35 & 36	
35	1	Barrel Weld Assembly 3.0" Cylinder	04560601
35	1	Barrel Weld Assembly 3.5" Cylinder	04560701
36	2	Cylinder Cross-Over Tube Assembly	04560801
37	2	<b>Rod W/Piston &amp; Head 3.0" Assembly</b>	<b>02553201</b>
37	2	<b>Rod W/Piston &amp; Head 3.5" Assembly</b>	<b>02553301</b>
-	-	Includes items 38-51	
38 <sup>(1)</sup>	1	Rod 45mm W/Block & Plate	02568501

(1) Part numbers and descriptions vary based on drive configuration and application.

## Cylinder Assembly

ID #	QUANTITY	DESCRIPTION	PART NUMBER
<b>Cylinder Assembly</b>			
-	1	<b>Head 3.0" Assembly Cylinder</b>	<b>03808501</b>
-	1	<b>Head 3.5" Assembly Cylinder</b>	<b>03811001</b>
-	-	Includes items 39-46	-
39	1	Head 3.0" Cylinder (Replace Old 01786201)	06372501
39	1	Head 3.5" Cylinder (Replace Old 02553501)	06375501
40	2	Wiper Rod 45mm Canned	84426600
41-1	1	Seal Rod Cylinder 45mm	84354200
41-2	1	Seal Backup Rod Cylinder 45mm	w/seal
42-1	1	Buffer Seal Rod Cylinder 45mm	84400201
42-2	1	Buffer Seal Backup Rod Cylinder 45mm	w/Buffer Seal
43-1	1	Wear Ring Rod Cylinder 45mm	84401105
43-2	1	PTFE Wear Ring Rod Cylinder 45mm (Blue)	84401205
44	1	Lock Wire 3.0" Head Cylinder	03812102
44	1	Lock Wire 3.5" Head Cylinder	03812104
45	1	O-Ring 232, (3.0" Cyl)	84384200
45	1	O-Ring 236, (3.5" Cyl)	84384600
46	1	O-Ring Backup 8-232, (3.0" Cyl)	84392400
46	1	O-Ring Backup 8-236, (3.5" Cyl)	84392800
-	1	<b>Piston 3.0" Assembly Cylinder</b>	<b>03808101</b>
-	1	<b>Piston 3.5" Assembly Cylinder</b>	<b>03810901</b>
-	-	Includes items 47-51	-
47	1	Piston 3.0" Cylinder	02564801
47	1	Piston 3.5" Cylinder	02553601
48	2	Seal Piston Cylinder 3.0"	84353600
48	2	Seal Piston Cylinder 3.5"	84353800
49 <sup>(2)</sup>	2	Seal Backup Piston Cylinder 3.0" & 3.5"	w/seal
50	1	Wear Ring Piston 3.0"	84404600
50	1	Wear Ring Piston 3.5"	84404800
51	1	Pin Drive Lock 3/16" x 1/2"	86650400
- <sup>(3)</sup>	1	<b>Old Seal Kit 3.0" Cylinder Metric</b>	<b>03877501</b>
- <sup>(3)</sup>	1	<b>New Seal Kit 3.0" Cylinder Metric</b>	<b>06528901</b>
- <sup>(3)</sup>	1	<b>Old Seal Kit 3.5" Cylinder Metric</b>	<b>03877601</b>
- <sup>(3)</sup>	1	<b>New Seal Kit 3.5" Cylinder Metric</b>	<b>06529001</b>
-	-	Includes items 40-46 & 48-50	-

(2) Backup included with seal.

(3) The seal kit includes all necessary items required to rebuild the entire cylinder. It does not include items such as the Rod or Piston.

### Hydraulic Tubes & Fittings

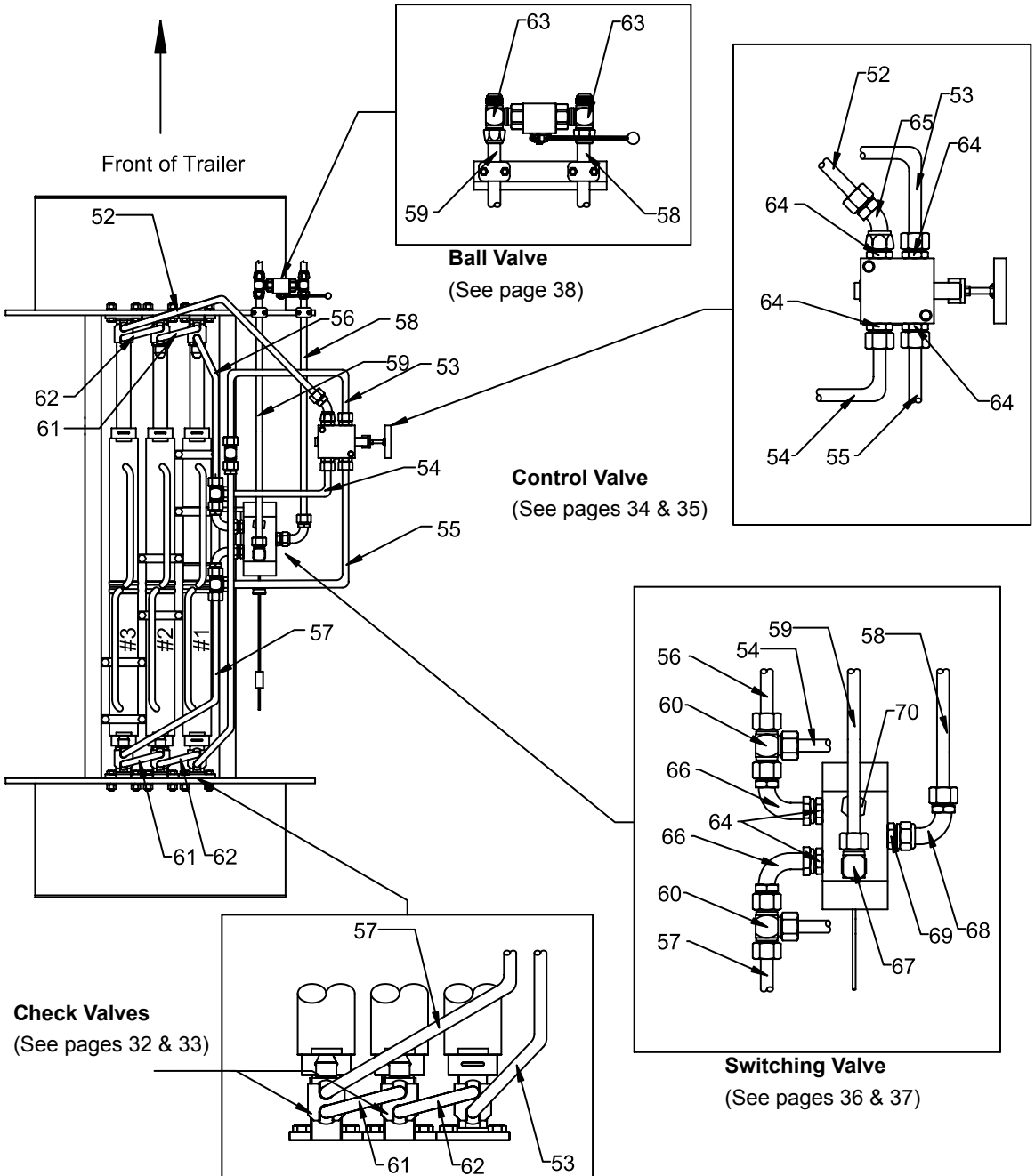

## Hydraulic Tubes & Fittings

ID #	QUANTITY	DESCRIPTION	PART NUMBER
<b>Hydraulic Tubes &amp; Fittings</b>			
-	-	<b>Hydraulic Tubes &amp; Fittings</b>	-
-	-	Includes items 52-70	-
52 <sup>(1)</sup>	1	Tube #52 Front of Cylinder #3 to CTV	03843501
53 <sup>(1)</sup>	1	Tube #53 Rear of Cylinder #1 to CTV	03843601
54	1	Tube #54 Control Valve to Front of SWV	03843701
55	1	Tube #55 Control Valve to Rear of SWV	03843801
56 <sup>(1)</sup>	1	Tube #56 SWV to Front of Cylinder #1	03816901
57 <sup>(1)</sup>	1	Tube #57 SWV to Rear of Cylinder #3	03817001
58	1	Tube #58 Switching Valve Pressure	03843901
59	1	Tube #59 Switching Valve Return	03844001
60	2	6602-12-12-12 Tee	84690300
61 <sup>(1)</sup>	2	Tube #61 CkV to CkV 4.5" Cylinder Centers	03813801
61 <sup>(1)</sup>	2	Tube #61 CkV to CkV 5.0" Cylinder Centers	03813802
62 <sup>(1)</sup>	2	Tube #62 CkV to Non-CkV 4.5" Cylinder Centers	03813901
62 <sup>(1)</sup>	2	Tube #62 CkV to Non-CkV 5.0" Cylinder Centers	03813902
63	2	2601-16-16-16 Tee	84677880
64	6	6400-12-12 Straight	84685000
65	1	63TA-12-12 Bent Stem 45°	84682600
66	2	63UA-12-12 Bent Stem 90°	84683100
67	1	6801-16-12 90°	84691700
68	1	63UA-16-16 Bent Stem 90°	84683200
69	1	6400-16-16 Straight	84685400
70	1	6408-12 O-Ring Plug	84686900

(1) Part numbers and descriptions vary based on drive configuration and application.

### Check Valve Assembly

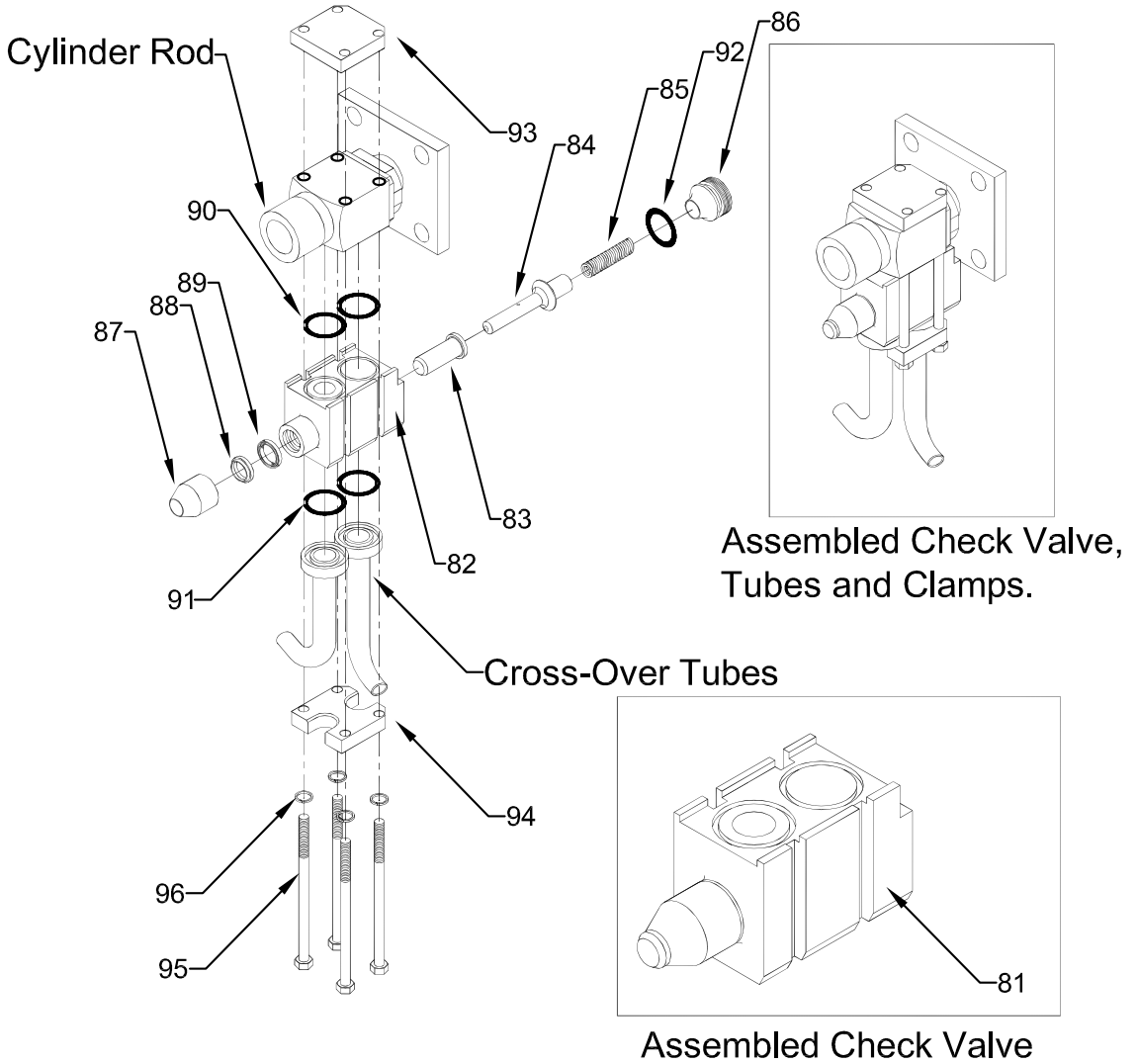

## Check Valve Assembly

ID #	QUANTITY	DESCRIPTION	PART NUMBER
<b>Check Valve Assembly</b>			
<b>81</b>	<b>1</b>	<b>Check Valve External Assembly</b>	<b>03709401</b>
-	-	Includes Items 82-92	-
82	1	Body Check Valve External	03654601
83	1	Plunger Check Valve External	01771101
84	1	Rod Check Valve External	01766901
85	1	Spring Check Valve External Large #B-18273	84453400
86	1	End Cap Check Valve External Threaded	03654501
-	<b>1</b>	<b>Seal Kit Check Valve External</b>	<b>03878101</b>
-	-	Includes items 87-92	-
87	1	Dust Boot Check Valve External	84801100
88	1	Plunger Wiper Check Valve External	84426800
89	1	Seal Rod 5/8"	84352200
90	2	O-Ring 122	84377800
91	2	O-Ring 214	84381600
92	1	O-Ring 916	84387800
-( <sup>1</sup> )	1	O-Ring 124	84378000
-( <sup>1</sup> )	1	Lock Wire Check Valve External	03889301
93	1	Clamp Top Check Valve External	02513001
94	1	Clamp Bottom Check Valve External	02513101
95	4	Bolt Hex GR5 5/16"x5 1/2"	86434500
96	4	Washer Lock 5/16"	86553000

(1) Not shown, for use with Check Valve Body part #01248601 equipped with lock wire end cap.

### Control Valve Assembly

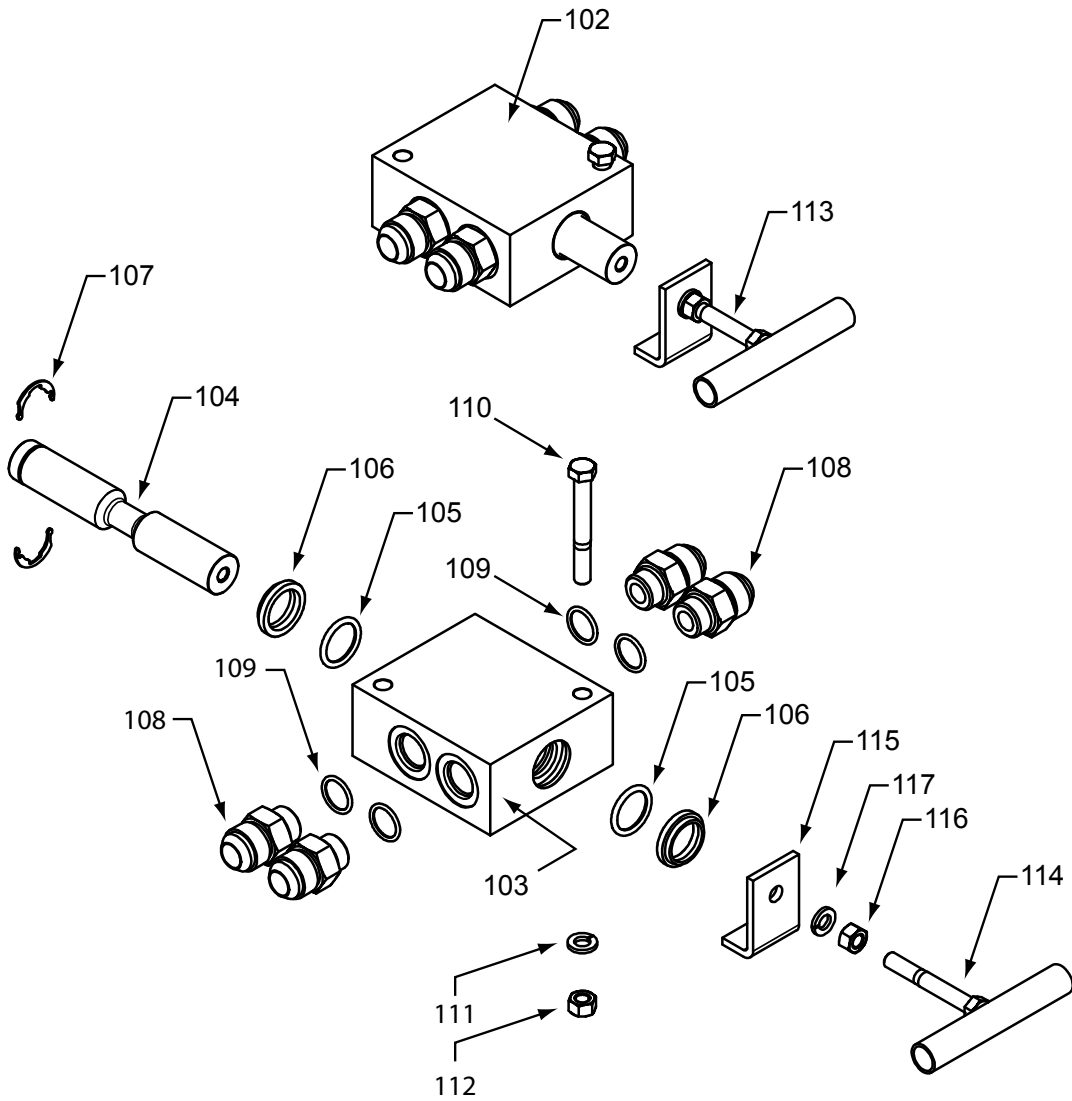

## Control Valve Assembly

<b>Control Valve Assembly</b>			
<b>102</b>	<b>1</b>	<b>Control Valve Load/Unload Assembly</b>	<b>02552701</b>
-	-	Includes items 103-109	-
103	1	Body Control Valve	01049501
104	1	Spool Control Valve	03423201
-	<b>1</b>	<b>Seal Kit Control Valve Load/Unload</b>	<b>03877901</b>
-	-	Includes items 105-107	-
105	2	O-Ring 214 B-70	84381800
106	2	Wiper 1" Rod	84427000
107	1	Snap Ring 2-Piece For Spool	84801000
108	4	6400-12-10 Straight	84684900
109	4	O-Ring 910	84387200
110	2	Bolt Hex GR5 3/8"x3"	86442000
111	2	Washer Lock 3/8"	86555000
112	2	Nut Hex 3/8"	86628500
<b>113</b>	<b>1</b>	<b>Handle Assembly Control Valve Load/Unload</b>	<b>02552601</b>
-	-	Includes items 114-117	-
114 <sup>(1)</sup>	1	"T" Handle	-
115 <sup>(1)</sup>	1	"T" Handle Plate	-
116	1	Nut Hex 3/8"	86628500
117	1	Washer Lock 3/8"	86555000

(1) Not sold separately. Included only with Control Valve Handle Assembly.

## Switching Valve Assembly

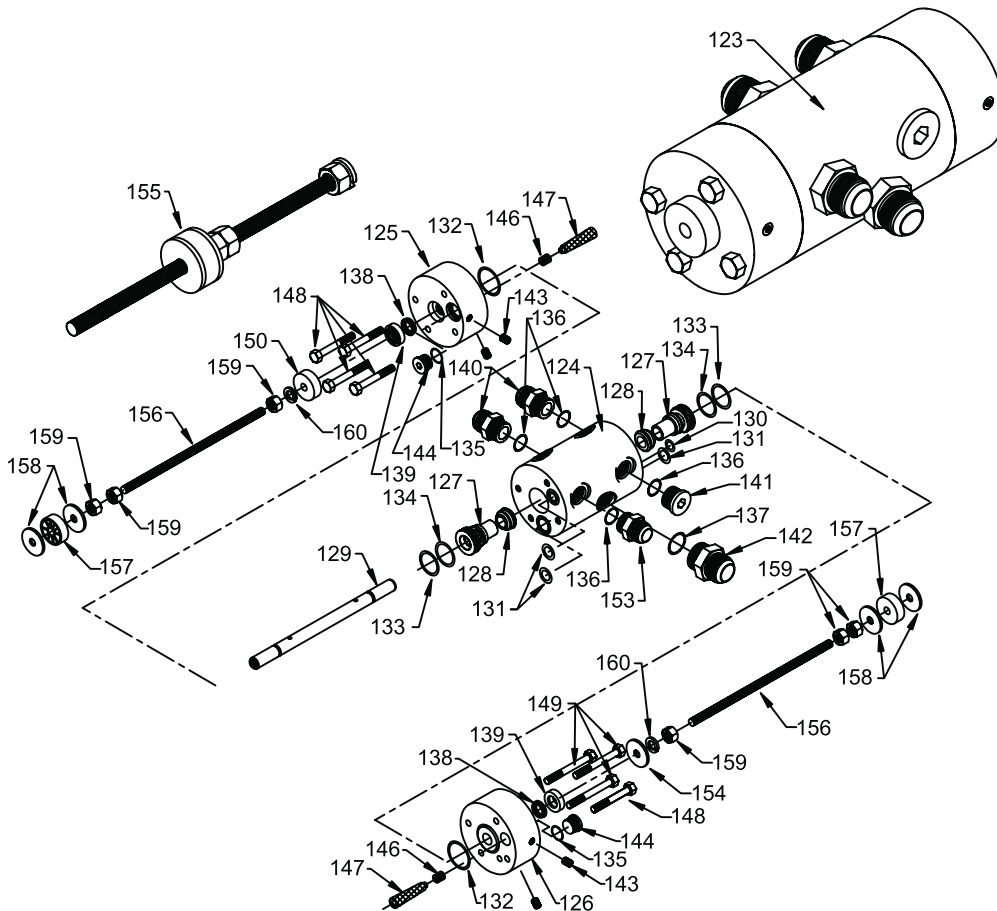

ID #	QUANTITY	DESCRIPTION	PART NUMBER
<b>Switching Valve Assembly</b>			
123 <sup>(1)</sup>	1	<b>Switching Valve Assembly SAE</b>	<b>03888901</b>
-	-	Includes Items 124-154	-
124 <sup>(1)</sup>	1	Body Switching Valve	04504601
125 <sup>(1)</sup>	1	End Cap Right Switching Valve	04504701
126 <sup>(1)</sup>	1	End Cap Left Switching Valve	04504801
127	2	Poppet Switching Valve	03718901
128	2	Ring Poppet Switching Valve	03718801
129	1	Rod Control Switching Valve	01335501
- <sup>(2)</sup>	1	<b>Seal Kit Switching Valve</b>	<b>03878001</b>
-	-	Includes items 130-139	-
130	1	O-Ring 111	84376200

(1) Part numbers vary for Switching Valves made before 1998.

(2) The Switching Valve Seal Kit contains all necessary components to rebuild all Switching Valve models.

### Switching Valve Assembly

ID #	QUANTITY	DESCRIPTION	PART NUMBER
131	3	O-Ring 117	84377000
132	2	O-Ring 126	84378200
133	2	O-Ring 216	84382200
134	2	O-Ring Backup 8-216	84391600
135	2	O-Ring 908	84387000
136	4	O-Ring 912	84387400
137	1	O-Ring 916	84387800
138	2	Seal Rod 5/8"	84352200
139	2	Wiper Canned 5/8" Rod	84427200
-(3)	3	O-Ring 011	84375200
-(3)	1	O-Ring 114	84376700
-(3)	2	O-Ring 124	84378000
-(3)	1	1/2" Pipe Plug Socket 7/8" Taper	84680790
140	2	6400-12-12 Straight	84685000
141	1	6408-12 M O-Ring Socket Plug	84687700
142	1	6400-16-16 Straight	84685400
143	4	1/8" Pipe Plug Socket 7/8" Taper	84680780
144	2	6408-08 M O-Ring Socket Plug	84687500
146	2	Spring S157	84451750
147	2	Filter Element CF0563-46	84012700
148	5	Bolt Hex GR5 3/8"x2 1/2"	86441000
149	3	Bolt Hex GR5 3/8"x3"	86442000
150	1	Cap Limit Switching Valve	02552101
153	1	6400-16-12 Straight	84685300
154	1	Washer Large OD 3/8"	86553500
<b>155</b>	<b>2</b>	<b>Rod Threaded Assembly Switching Valve</b>	<b>03869701</b>
-	-	Includes Items 156-160	-
156	1	Threaded Rod 3/8"x18"	86603000
157	1	Switching Valve Grommet	83217500
158	2	Washer Large OD 3/8"	86553500
159	3	Nut Hex 3/8"	86628500
160	1	Washer Lock 3/8"	86555000

(3) Not shown. For use with previous model Switching Valve.

### Ball Valve Assembly

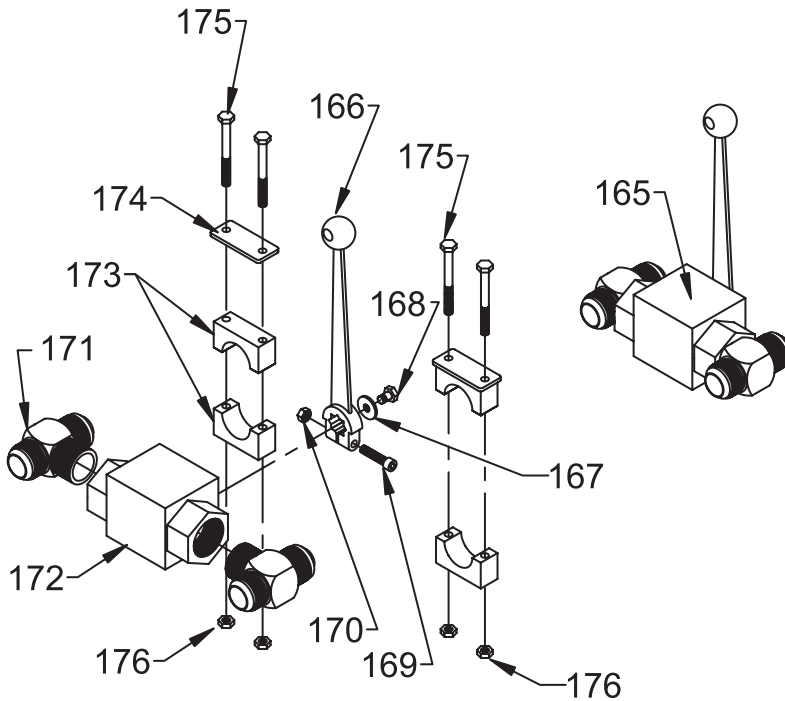

ID #	QUANTITY	DESCRIPTION	PART NUMBER
<b>Ball Valve Assembly</b>			
165	1	<b>Ball Valve 1" W/ Tees &amp; Handle</b>	<b>84802600</b>
-	-	Includes items 166-172	-
166	1	Handle Ball Valve	84802900
167	1	Washer Flat 6mm	w/ball valve
168	1	Bolt Hex GR8 6mmx1mmx10mm	w/ball valve
169	1	Bolt Socket Head GR8 6mmx1mmx30mm	w/handle
170	1	Nut Hex 6mmx1mm	w/handle
171	2	2601-16-16-16 Tee	84677880
172	1	Ball Valve Assembly 1"	84802800
-	<b>2</b>	<b>Clamp Hydraulic Tube 1" Kit</b>	<b>04631101</b>
-	-	Includes items 173-176	-
173 <sup>(1)</sup>	1	Clamp Hydraulic Tube 1" Set	84750300
174	1	Plate Clamp Tube Top COP-3	84751200
175	2	Bolt Hex GR5 1/4"x2 1/4"	86419500
176	2	Nut Hex Nylock 1/4"	86626000

### Front Shield Assembly

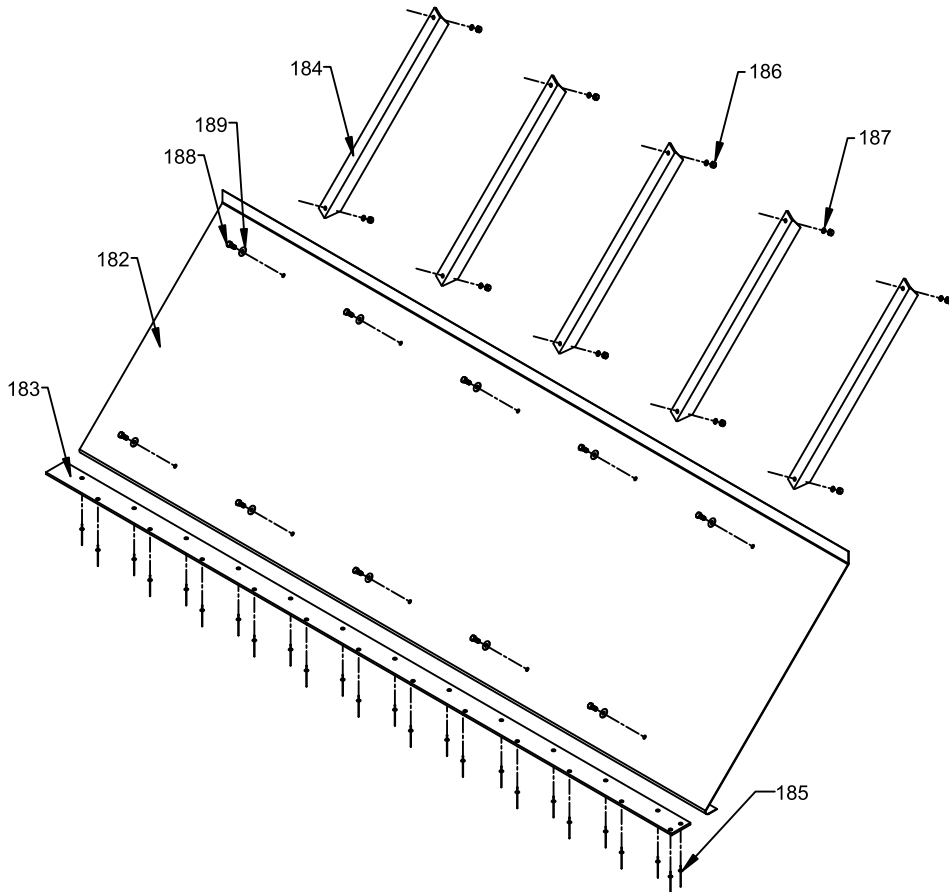

ID #	QUANTITY	DESCRIPTION
<b>FRONT SHIELD ASSEMBLY</b>		
<b>-(1)</b>	<b>1</b>	<b>Front Shield 96" Wide Assembly</b>
-	-	Includes items 182-189
182 <sup>(1)</sup>	1	Front Shield 96" Wide 14 Gauge
183 <sup>(1)</sup>	1	Bearing Strip Front Shield 1/4"x2 7/8"
184	5	Stiffener Angle Front Shield 1 1/2"x 1 1/2"x3/16"
185 <sup>(2)</sup>	25	Rivet 3/16"x1/2"
186	10	Nut Hex 10mm
187	10	Washer Lock 10mm
188	10	Bolt Hex 8.8 10mm x 20mm
189	10	Washer Large OD 3/8"

(1) Part numbers and descriptions vary based on trailer width and application.

(2) Quantity varies based on trailer width and application.

## Floor Components

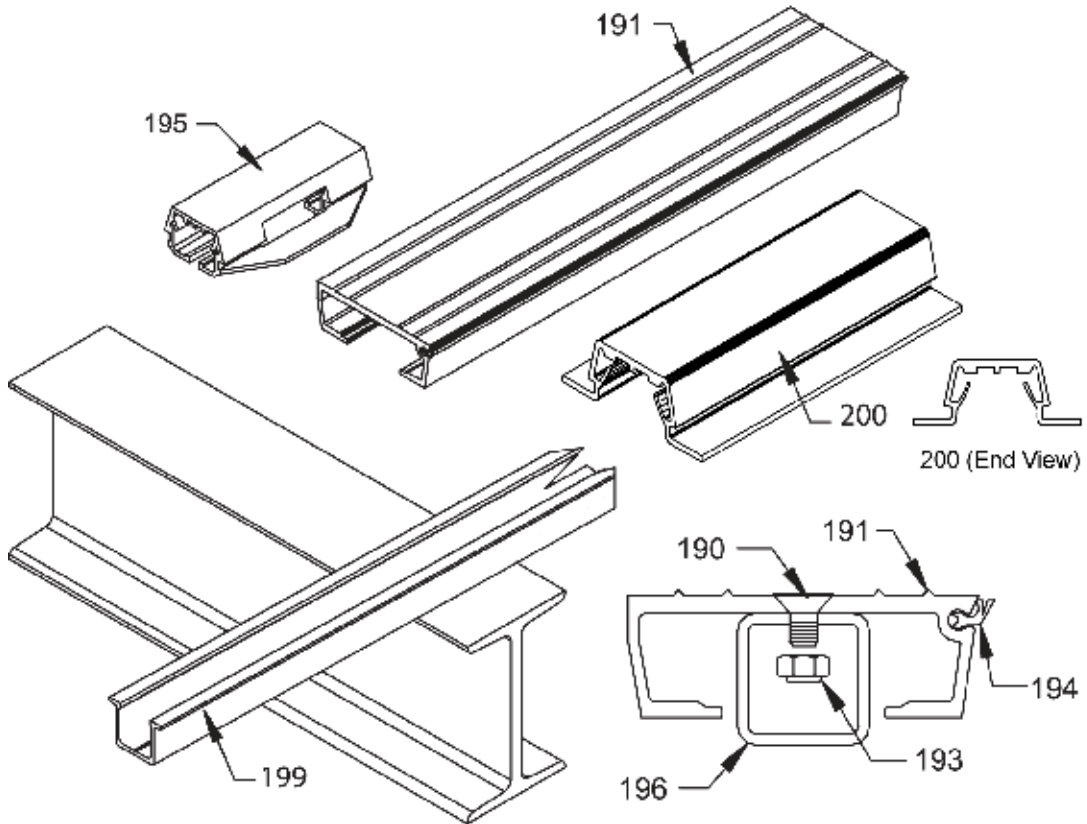

ID #	QUANTITY	DESCRIPTION
<b>FLOOR COMPONENTS</b>		
-	-	<b>FLOOR COMPONENTS</b>
-	-	Includes items 190, 191, 193-197, 199, 200
190 <sup>(1)</sup>	-	Bolt Hex GR5 5/16"x 2 1/4"
191 <sup>(1)</sup>	-	Slat 3.5" 2295 1/2" Impact® Series 1212
193 <sup>(1)</sup>	-	Nut Hex Nylock 5/16"
194 <sup>(1)</sup>	-	Seal Floor Bent "Y"
195 <sup>(1)</sup>	-	Bearing 3.5" Floor Slat
196 <sup>(1)</sup>	-	Drive Shoe
199 <sup>(1)(2)</sup>	-	2469 Aluminum Channel
198 <sup>(1)</sup>	-	Splash Guard Hold-Down Bearing

(1) Part numbers and descriptions vary based on trailer width and application.

(2) Channel is also available in 44' lengths (8224694400) and 48' lengths (8224694800)

\* The last four digits in a ten part number refers to length in feet and inches (Example 8222954305 is 43'05" long).

## Floor Components

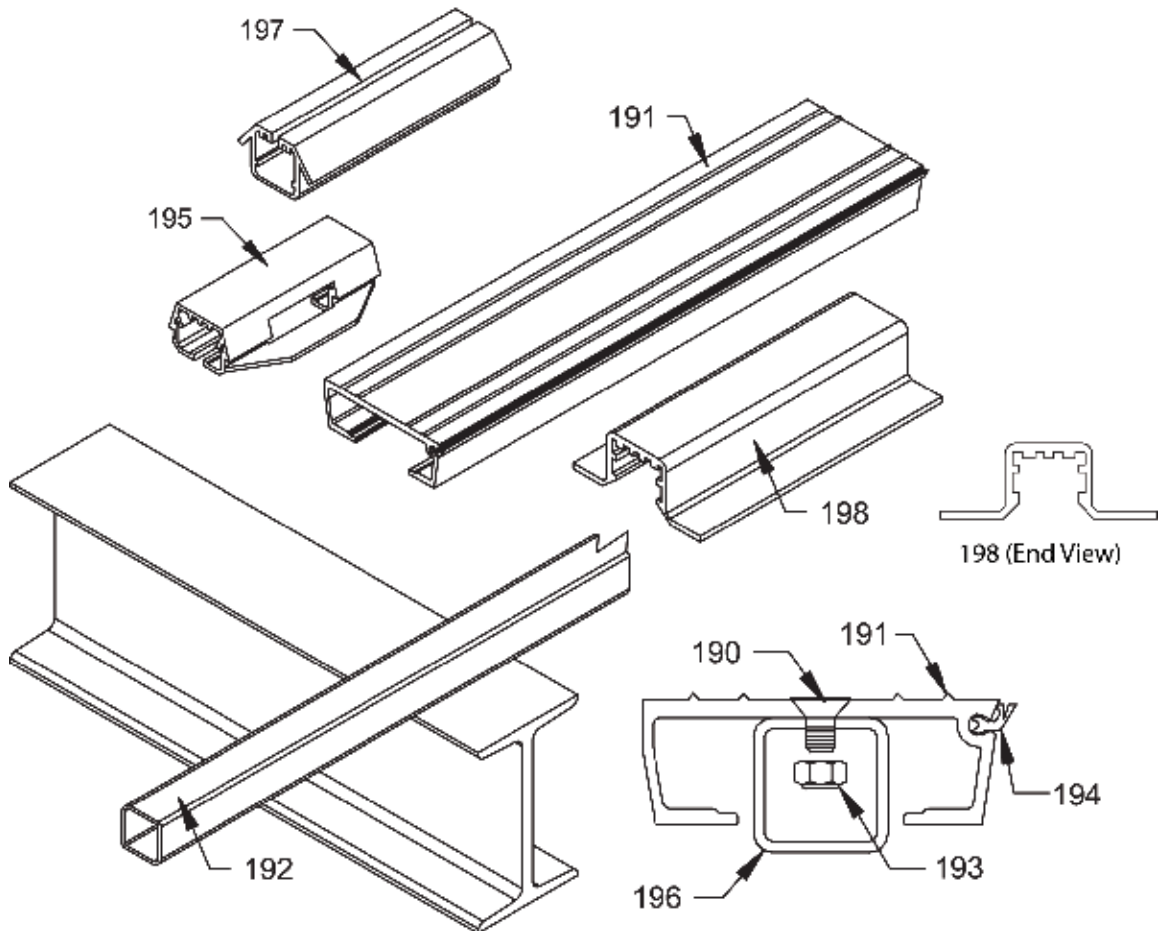

ID #	QUANTITY	DESCRIPTION
<b>FLOOR COMPONENTS</b>		
-	-	<b>FLOOR COMPONENTS</b>
-	-	Includes items 190-198
190 <sup>(1)</sup>	-	Bolt Hex GR5 5/16"x1"
191 <sup>(1)</sup>	-	Slat 3.5" 2295 1/2" Impact® Series
192 <sup>(1)</sup>	-	Subdeck 1"x1"x.063"x20' Steel Tube
193 <sup>(1)</sup>	-	Nut Hex Nylock 5/16"
194 <sup>(1)</sup>	-	Seal Floor Bent "Y" 1212
195 <sup>(1)</sup>	-	Bearing 3.5" Floor Slat
196 <sup>(1)</sup>	-	Drive Shoe
197 <sup>(1)</sup>	-	Bearing Hold Down 3.5" Floor Slat
198 <sup>(1)</sup>	-	Splash Guard Bearing (Not Hold-Down)

(1) Part numbers and descriptions vary based on trailer width and application.

\* The last four digits in a ten part number refers to length in feet and inches (Example 8222954305 is 43'05" long).

**Maintenance For Your New  
KEITH® RUNNING FLOOR II® and Hydraulic Wet Kit**

1. For proper operation of your new RUNNING FLOOR II® equipped trailer and wet kit, make sure the pressure and return lines are hooked up correctly. It is important to periodically inspect hoses and connectors for damage and contamination. Clean all dirt and water from connectors before hooking up.
2. Change the hydraulic return filter element after the first six (6) hours of operation and then every six (6) months. This may vary with the operating environment.
3. During the first two (2) weeks of operation, it will be necessary to check and tighten all floor bolts. Floor bolts should be checked regularly for proper torque, in accordance with a preventive maintenance program, as loose floor bolts will cause serious damage to floor slats.
4. After the first week of operation, you must check and tighten the lower cross-drive clamp bolts that fasten the cross-drives to the cylinder. Also check the end cylinder rod plate bolts that fasten the cylinders to the drive frame.
5. During the first several weeks of operation, examine the check valve and tube clamps regularly to ensure that they are securely fastened.
6. It is recommended to pressure wash the top of the floor slats and seal every six months.

<b>Bolt Description</b>	<b>Recommended Bolt Torque Values</b>	<b>Torque</b>
Bolt Floor 5/16" FHCS	82° flat head floor bolt	22 FT-LBS
Bolt Floor 3/8" FHCS	82° flat head floor bolt	42 FT-LBS
Bolt Hex 5/8" HCS	Lower cross-drive clamp bolt (Over torque may distort the barrel enough to bind the piston.)	135 FT-LBS
Bolt Hex 5/8" HCS	Rod end plates	135 FT-LBS
Bolt Hex 5/16" HCS	Check valve and tube clamp bolts	20 FT-LBS

**Problems and Trouble-Shooting**

KEITH Mfg. Co. 24-hour Fax Service (541) 475-2169  
 KEITH Mfg. Co. Customer Service and Support (800) 547-6161 or (541) 475-3802  
 Monday - Friday, 7 am to 4 pm Pacific Standard Time  
 Email: techdept@keithwalkingfloor.com

**Before you call, please review the following:**

1. See start-up check list on page 11.  
 Re-checking items on this list can solve most problems.
2. We will be better able to help solve any problems if you have the information indicated below before you call.
  - a. Drive Model Number
  - b. Drive Serial Number
  - c. Number of floor slats
  - d. Trailer make
  - e. Cylinder bore size

**PLEASE FILL OUT AND RETURN IMMEDIATELY TO  
KEITH Mfg. Co.**

The warranty registration card must be completed and on file at KEITH Mfg. Co. in order for the warranty period to begin on the purchase date. If no purchase date is registered, the beginning of the warranty will be the date of the manufacture if no other date can be determined.

Please make sure the serial number listed on the card coincides with the serial number plate on the drive unit.

**Please print or type  
KEITH® RUNNING FLOOR II® Warranty Registration Card**

Purchaser		
Address		Phone
City		State/Prov.
Country		Postal Code
Original Purchase Date of System		
KEITH Model No.		
KEITH Serial No. (See page 8 for location guide)		
Installed in:	New Trailer	Used Trailer
Dealer Name & Location		
Type of Material Unloaded		

**I have fully read the KEITH Mfg. Co. warranty information and I/we fully understand and agree to the terms of the warranty.**

Signature \_\_\_\_\_ Date \_\_\_\_\_

**Note: To validate the warranty, this registration card must be filled out completely and returned to KEITH Mfg. Co. within ten (10) days of purchase and/or installation.**

**Please fax, mail or email this warranty registration information to KEITH Mfg. Co. at:**

**Warranty Registration  
KEITH Mfg. Co.  
P.O. Box 1  
Madras, OR 97741-0001  
Fax: (541) 475-2169  
Email: techdept@keithwalkingfloor.com**

CUT HERE



## Warranty Return Policy

1. Contact KEITH Mfg. Co. at 1-800-547-6161 or techdept@keithwalkingfloor.com for a "Returned Goods Authorization" (RGA) number before returning any item for repair or replacement. The following information is needed to ensure parts are returned as quickly as possible.

- |                 |                              |
|-----------------|------------------------------|
| a. Company name | e. Part number               |
| b. Contact name | f. Quantity                  |
| c. Address      | g. Reason for return         |
| d. Phone number | h. Customer's account number |

2. Prior approval and a RGA number is needed when returning any unused product for credit. Make sure the RGA number is on the outside of the shipping carton and all paperwork is included. Return all material on a Freight Prepaid Basis.

### **!!CAUTION!!**

#### **To prevent Possible Injury or Death**

##### **DO NOT:**

1. Operate the floor with the doors closed.
2. Stand behind the trailer or in the discharge area when floor is operating.
3. Make adjustments to the unloading mechanism with floor operating.
4. Operate the unloader when protective covers and screens are not in place.
5. Go underneath the trailer when floor is operating.
6. Leave the trailer unattended while the unloader is in operation.

##### **ALWAYS:**

1. Disengage the trailer from the hydraulic power unit (P.T.O.) before service and maintenance.
2. Shut off the power supply before going underneath the trailer.
3. Stay away from any oil leaks when hydraulic pressure is high.
4. Shut off the hydraulic power take off unit (P.T.O.) before moving the trailer.
5. Make certain no one is in the trailer during loading.

**!!Keep your hands, body parts and loose clothing away from the floor slats and drive mechanism when the unloading system is in operation!!**

